



SHELL-O-MATIC

PRO DUCT CATALOG

YOUR SHELLROOM SPECIALIST

+1.514.323.0868 | shellomatic.com | info@shellomatic.com

AUTOMATION IN THE SHELL ROOM. LET US MAKE IT WORK FOR YOU.

Shell-O-Matic designs and manufactures specialized equipment for the investment casting industry.

Originally, Shell-O-Matic was established as an in-house engineering group for Cercast Inc. (today Howmet/Alcoa), a producer of aluminum investment castings with several plants in North America and Europe.

Shell-O-Matic was incorporated as a separate company in 1978 to serve the general Investment Foundry market.

Located in Montreal, Canada, Shell-O-Matic today produces a range of high quality equipment for ceramic shell production.

Over the years this equipment has found good acceptance within the entire investment casting industry ranging from commercial to aerospace type applications.

REASON FOR AUTOMATION IN THE SHELL ROOM

1. Uniform shell quality, less material wasted. A programmable machine (robot) will give a consistent, repeatable result.
2. Due to the consistent shell, less or no rework is needed in the finishing department.
3. Ability to increase the size of the mold, regardless of the weight. This increases the value per mold.
4. Ability to produce large and heavy parts.
5. Control the drying process, again to improve the shell quality.
6. Save labor cost. A typical production cell can be operated by one person per shift.

The background of the page is a light gray technical drawing. It features various mechanical and electrical symbols, including gears, shafts, bearings, and electrical components like a capacitor and a battery. The lines are thin and white, creating a complex, layered pattern behind the text.

MAINTENANCE

MAINTENANCE AND SERVICE FROM THE INDUSTRY SPECIALIST

CUSTOMIZED MAINTENANCE SOLUTIONS THAT ARE TAILORED TO YOUR NEEDS

- » Mechanical, electrical and software engineers are a videoconference call away
- » Onsite visits
- » Discount on parts available on purchase of maintenance package
- » Maximize your equipment performance
- » Significantly reduce your production down time
- » Extend your equipment lifetime
- » Spare part kits available
- » Equipment extended warranty available
- » Advice on new technologies that can improve your operations
- » Preventative maintenance
- » Shell-O-Matic has an extensive range of spare parts in stock
- » Upgrades available for your production line and equipment

 +1.514.323.0868

EMERGENCY 24/7 SERVICE

The emergency 24/7 service will allow your team to access one of our specialists at anytime from anywhere to help answer their questions immediately.

On demand video conferencing support available anytime.

- » Our specialized technicians will be able to answer in real time your needs to help you keep the production line going and minimize down time.

We specialize in:

- Mechanical system
- Electrical system
- System software
- Automation
- And everything in between



**CUSTOMIZED MAINTENANCE
SOLUTIONS TAILORED
TO YOUR NEEDS**

 **+1.514.323.0868**

ROBOTS

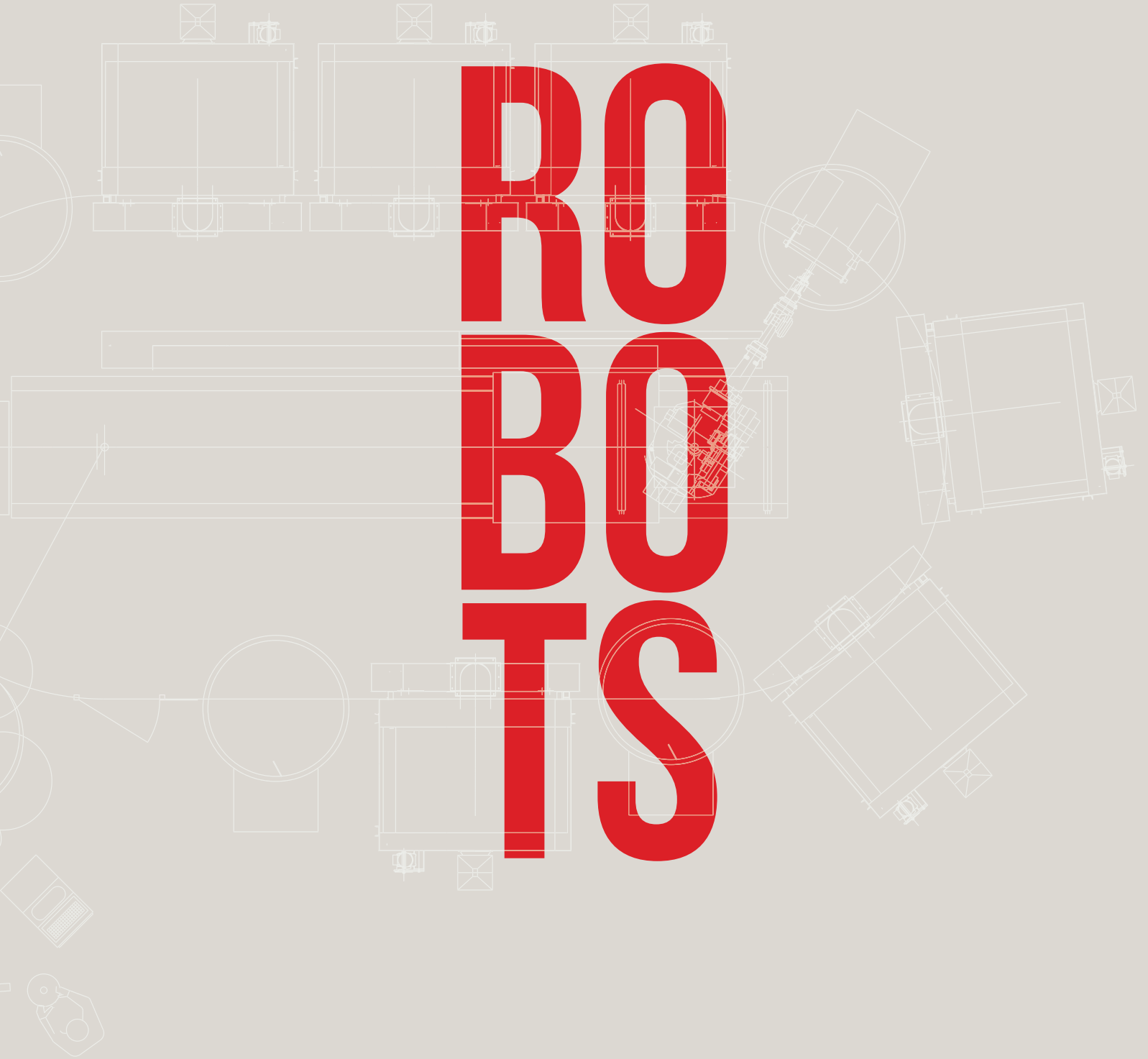

IRB 8700

THE LARGEST ROBOT ABB HAS EVER MADE.

In designing the IRB 8700 the focus was on delivering a very reliable robot with a low total cost of ownership. Through a combination of robust design elements, including simpler parts configurations where possible, ABB Robotics applied decades of engineering experience to combine the high performance customers require with low overall maintenance needs.

IN ADDITION, THE IRB 8700 DELIVERS 25% FASTER SPEEDS THAN ANY OTHER ROBOT IN THIS CLASS SIZE.

Features and benefits:

- » High payloads up to 1000 kg with the wrist down
- » 25% faster speeds than other robots in this size class
- » Highly reliable with simplified design and Foundry Plus 2 protection standard
- » Built around LeanID for reduced wear on dress packs and ease of simulation
- » Built using non-hazardous materials

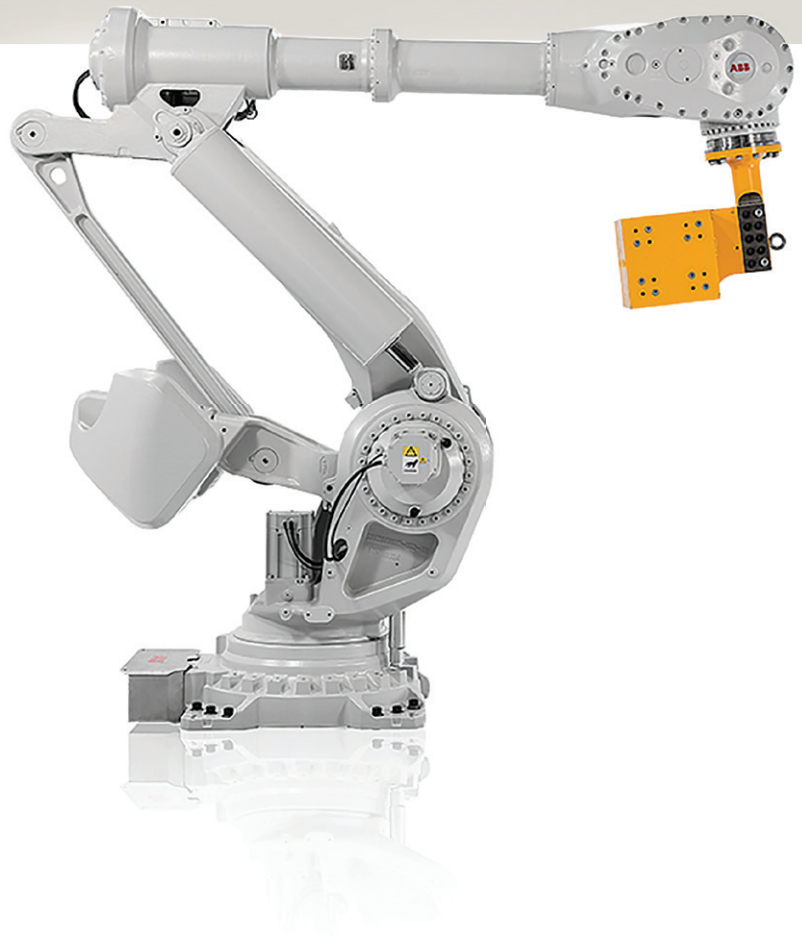

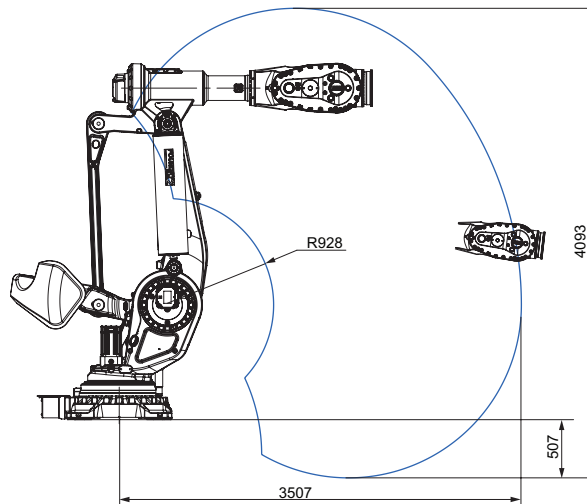
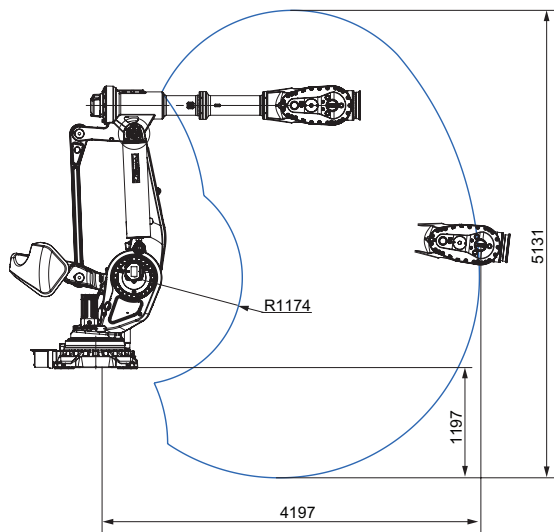

SPECIFICATION				
ROBOT VERSIONS	REACH	HANDLING CAPACITY	CENTER OF GRAVITY	WRIST TORQUE
Without Lean ID				
IRB 8700-800/3.50	3.50 m	800 kg	460 mm	6043 Nm
IRB 8700-550/4.20	4.20 m	550 kg	460 mm	5279 Nm
With Lean ID				
IRB 8700-800/3.50	3.50 m	630 kg	460 mm	6043 Nm
IRB 8700-550/4.20	4.20 m	475 kg	460 mm	5279 Nm
Extra loads can be mounted on all variants. 50 kg on upper arm and 500 kg on frame of axis 1.				
Number of axes		6		
Protection		Complete robot IP67		
Mounting		Floor mounted		
IRC5 Controller variants		Single cabinet		

ELECTRICAL CONNECTIONS	
Supply voltage	200-600 V, 50/60 Hz
Energy consumption ISO-Cube	3.93 kW

PHYSICAL	
Dimensions robot base	1175 x 920 mm
Weight	4527 - 4575 kg

PERFORMANCE		
	IRB 8700-800/3.50	IRB 8700-550/4.20
Pos. repeatability RP	0.05 mm	0.08 mm
Path repeatability RT	0.07 mm	0.14 mm

MAXIMUM AXIS SPEED						
	AXIS 1	AXIS 2	AXIS 3	AXIS 4	AXIS 5	AXIS 6
IRB 8700-800/3.50	75°/s	60°/s	60°/s	85°/s	85°/s	115°/s
IRB 8700-550/4.20	75°/s	60°/s	60°/s	85°/s	85°/s	115°/s

IRB 7600

A NEW WORLD OF POSSIBILITIES OPENS UP WITH ABB'S POWER ROBOT FAMILY.

It comes in several variants, up to 630 kg handling capacities. The IRB 7600 is ideal for weighty applications, regardless of industry. Characteristics such as high available torque and inertia capability, rigid design and powerful acceleration have earned this market leader its "Power Robot" title.

- » Reliable - High production up time
- » Security - A safe investment
- » Fast - Short cycle times
- » Accurate - Consistent parts quality
- » Strong - Maximized utilization
- » Robust - Harsh production environment
- » Versatile - Flexible integration and production

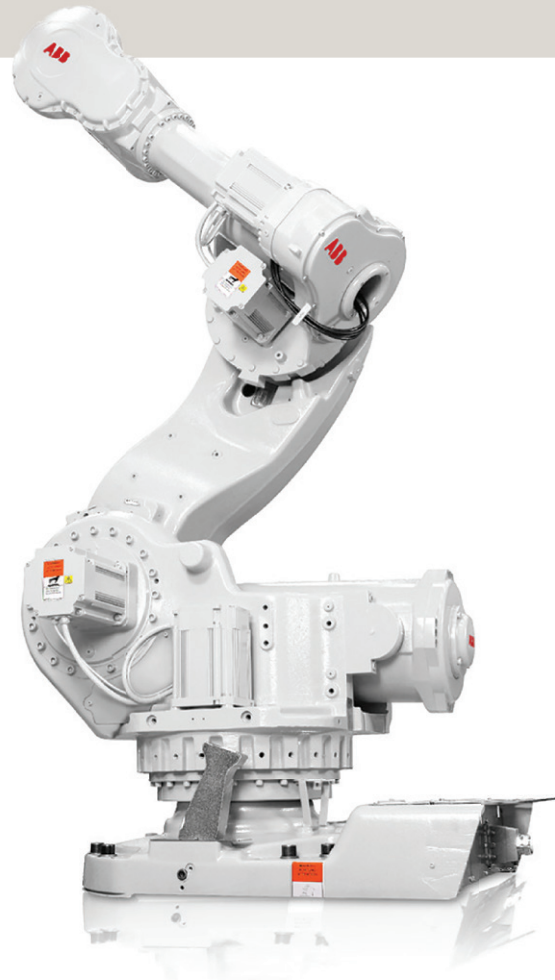

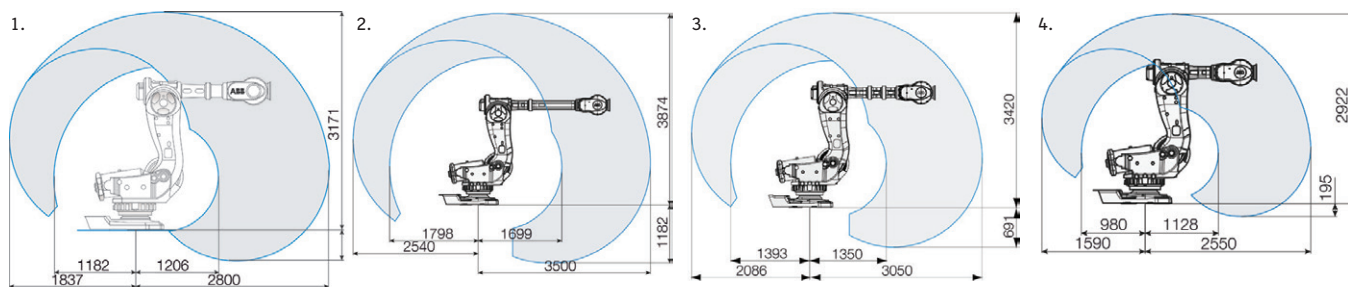

1. IRB 7600-340/2.8 | 2. IRB 7600-150/3.5 | 3. IRB 7600-325/3.1 | 4. IRB 7600-400/2.55/IRB 7600-500/2.55

SPECIFICATION

ROBOT VERSIONS	REACH	HANDLING CAPACITY	CENTER OF GRAVITY	MAX. WRIST TORQUE
IRB				
IRB 7600-500	2.55 m	500 kg	360 mm	3010 Nm
IRB 7600-400	2.55 m	400 kg	512 mm	3010 Nm
IRB 7600-340	2.8 m	340 kg	360 mm	2750 Nm
IRB 7600-325	3.1 m	325 kg	360 mm	2680 Nm
IRB 7600-150	3.5 m	150 kg	360 mm	1880 Nm
(IRB 7600-150 loaded with 100 kg 1660 mm)				
Extra loads can be mounted on all variants 50 kg on upper arm and 550 kg on frame of axis 1.				
Number of axes		6		
IRC5 Controller variants		Single cabinet, PMC		

ENVIRONMENT

AMBIENT TEMPERATURE FOR MECHANICAL UNIT

During operation	+5 °C (41 °F) up to +50 °C (122 °F)
During transportation & storage for short periods (max 24 h)	-25 °C (13 °F) up to +55 °C (131 °F) up to +70 °C (158 °F)
Relative humidity	Max 95%
Degree of protection	
Manipulator	Standard: IP67, Option: Foundry Plus 2
Controller	Air cooled
Noise level	Max 73 dB (A)
Safety	Double circuits with supervision, emergency stops and safety functions, 3-positions enable device.
Emission	EMC/EMI-shielded

PERFORMANCE

AXIS WORKING RANGE

Axis 1 Rotation	+180° to -180°
Axis 2 Arm	+85° to -60°
Axis 3 Arm	+60° to -180°
Axis 4 Wrist	+300° to -300°
Axis 5 Bend	+100° to -100°
Axis 6 Turn	+360° to -360°

AXIS MAX SPEED

	325/500 KG	400 KG	340 KG	150 KG
Axis 1	75°/s	75°/s	75°/s	100°/s
Axis 2	50°/s	60°/s	60°/s	60°/s
Axis 3	55°/s	60°/s	60°/s	60°/s
Axis 4	100°/s	100°/s	100°/s	100°/s
Axis 5	100°/s	100°/s	100°/s	100°/s
Axis 6	160°/s	160°/s	160°/s	190°/s

ELECTRICAL CONNECTIONS

Supply voltage	200-600 V, 50/60 Hz
----------------	---------------------

PHYSICAL

Dimensions robot base	1206.5 x 791 mm
Weight	2.400-2.450 kg

IRB 6700

THE IRB 6700 FAMILY OF ROBOTS IS A NATURAL EVOLUTION FOLLOWING 40 YEARS OF LARGE ROBOT HERITAGE AT ABB.

This 7th generation of large ABB robots features a multitude of next generation improvements derived from intimate customer relationships and exhaustive engineering studies. The IRB 6700 is more robust than its predecessor and maintenance has been simplified, making it the highest performing robot for the lowest total cost of ownership in the 150-300 kg class.

Features and benefits:

- » Increased service intervals and decreased service times
- » Longer uptime—mean time between failures: 400,000 hours
- » Available with Lean ID for cost effectively increasing dress pack lifetimes
- » More robust with a rigid structure and a new generation of motors and compact gearboxes
- » Increased speed and shorter cycle times—on average 5 percent faster
- » Improved accuracy and higher payloads
- » Built to operate in the harshest environments—available with Foundry Plus 2 package
- » 15 percent lower power consumption



IRB 6700-200/2.60

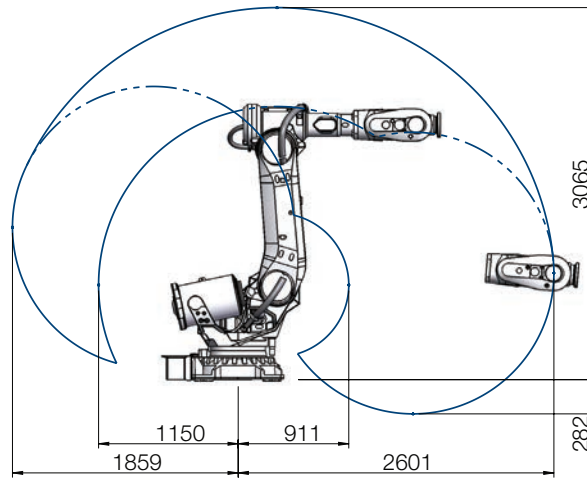

SPECIFICATION WITHOUT LEANID					SPECIFICATION WITH LEANID				
ROBOT VERSIONS	REACH	HANDLING CAPACITY	CENTER OF GRAVITY	WRIST TORQUE	ROBOT VERSIONS	REACH	HANDLING CAPACITY	CENTER OF GRAVITY	WRIST TORQUE
IRB					IRB				
6700-200	2.60 m	200 kg	300 mm	981 Nm	6700-200	2.60 m	175 kg	300 mm	981 Nm
6700-155	2.85 m	155 kg	300 mm	927 Nm	6700-155	2.85 m	140 kg	300 mm	927 Nm
6700-235	2.65 m	235 kg	300 mm	1324 Nm	6700-235	2.65 m	220 kg	300 mm	1324 Nm
6700-205	2.80 m	205 kg	300 mm	1263 Nm	6700-205	2.80 m	200 kg	300 mm	1263 Nm
6700-175	3.05 m	175 kg	300 mm	1179 Nm	6700-175	3.05 m	155 kg	300 mm	1179 Nm
6700-150	3.20 m	150 kg	300 mm	1135 Nm	6700-150	3.20 m	145 kg	300 mm	1135 Nm
6700-300	2.70 m	300 kg	300 mm	1825 Nm	6700-300	2.70 m	270 kg	300 mm	1825 Nm
6700-245	3.00 m	245 kg	300 mm	1693 Nm	6700-245	3.00 m	220 kg	300 mm	1693 Nm
Extra loads can be mounted on all variants 50 kg on upper arm and 250 kg on frame of axis 1.					Extra loads can be mounted on all variants 50 kg on upper arm and 250 kg on frame of axis 1.				
Number of axes		6			Number of axes		6		
Protection		Complete robot IP 67			Protection		Complete robot IP 67		
Mounting		Floor mounted			Mounting		Floor mounted		
IRC5 Controller variants		Single cabinet, Panel Mounted Controller			IRC5 Controller variants		Single cabinet, Panel Mounted Controller		

PERFORMANCE									
	6700-200	6700-155	6700-235	6700-245	6700-205	6700-175	6700-150	6700-300	
Pos. repeatability RP (mm)	0.10	0.10	0.10	0.10	0.10	0.10	0.10	0.10	0.10
Path repeatability RT (mm)	0.06	0.12	0.08	0.12	0.08	0.12	0.14	0.07	

SHELL-O-MATIC-TYPE ROBOTS

HEAVY DUTY DIPPING ROBOT

SHELL-O-MATIC-TYPE ROBOTS HAVE BEEN DESIGNED SPECIFICALLY FOR THE SHELL-BUILDING PROCESS AND ARE ESPECIALLY SUITED FOR HEAVY LOADS, UP TO 1500 LBS / 675 KG.

Before the era of the articulated robot, Shell-O-Matic was the first to introduce electrically driven robots in the investment casting industry back in 1973. These robots were designed and built by Shell-O-Matic specifically for the industry needs.

This design has now evolved for more than 40 years and has proven its benefits to our clients with over 250 robots installed so far all over the globe. Those robots are still selected by our clients today due to their ease of maintenance, simplicity and reliability. Furthermore, their construction is perfectly suited for heavy weight lifting capacity where they are more cost effective than articulated robots.

The product line includes:

- » 3 robot models respectively suited for 205 Kg, 365 Kg and 680 Kg.
- » Embedded Shell-O-Matic traverse axis with length design to suit your process complexity.
- » Simple and convenient manual control mode or fully automatic mode.
- » Smooth and fast motion.
- » Made from standard industrial components available worldwide.



With these robots we also deliver turnkey systems including:

- » Multi robot integration to maximize your factory throughput.
- » Industry-renowned gripper systems selected or adapted to your needs. Proven designs with many grippers having more than 25 years of continuous operation.
- » Integration of the robot with the surrounding process equipment (including existing equipment used in your factory).
- » Simple human machine interface in the language of your choice.
- » Robot cell safety system matching your local safety codes.
- » Worldwide training and support by Shell-O-Matic investment casting robotic experts.

THE SHELL-O-MATIC DIPPING ROBOT

- A Vertical, depending on application
- B Index (swing) 360° +
- C Tilt -30° to +180°
- D Rotation, continuous, reversible
- E Traverse, depending on application

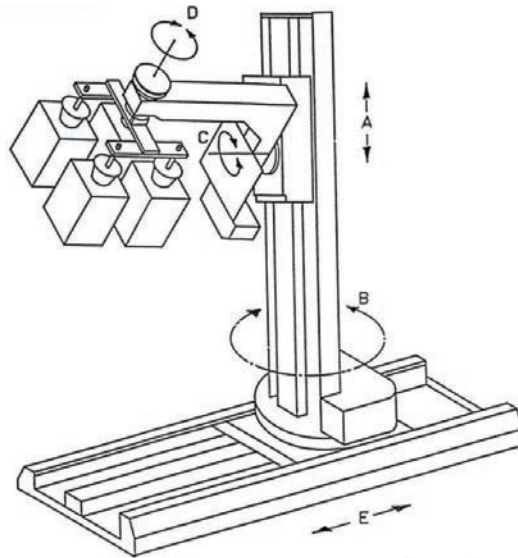

THE SHELL-O-MATIC SYSTEM

The unique Shell-O-Matic tilt axis makes it possible to rotate the parts directly over the tank - without complex programming.

The same simple movement helps to manipulate the molds inside a rainfallsander in an easy way.

The straight linear vertical motion makes it easy to follow the wall of the tanks - all without complex programming.

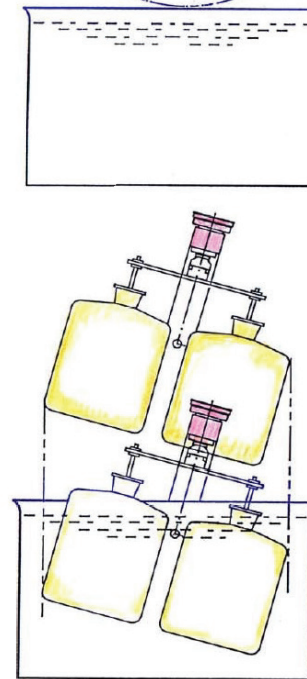
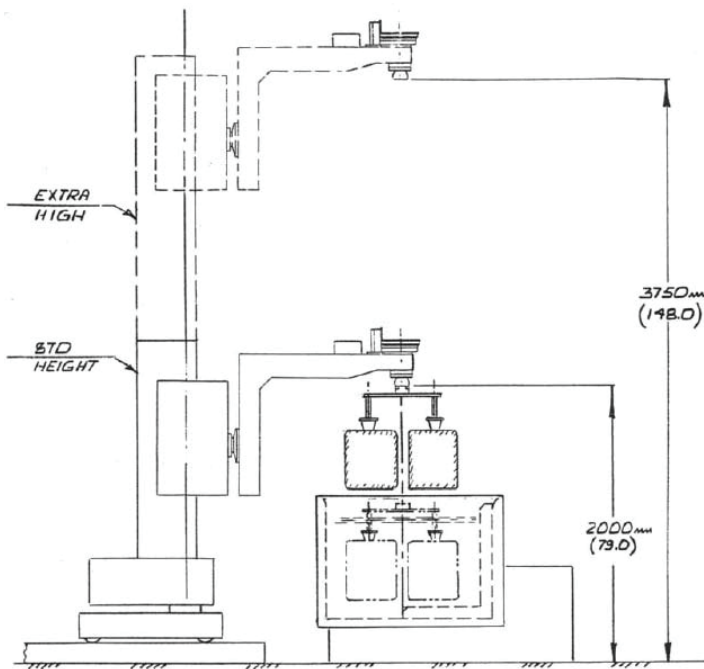
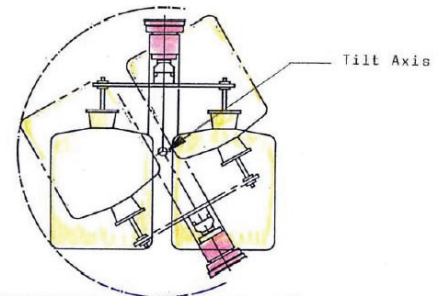

FANUC M-2000iA™ SERIES

HEAVY CAPACITY ROBOT SYSTEMS

WHEN SHELL-O-MATIC CREATED ITS ROBOT PRODUCT LINE, WE INCLUDED A MODEL CAPABLE OF HANDLING MOLDS OF 680KG/1500LBS.

FANUC Robotics' M-2000iA series robot is engineered for applications which cannot be handled by traditional robots due to work piece size or distances they must be moved. The world's leading supplier of robots has now greatly expanded robot applications with the M-2000iA series. The M-2000iA series is the world's largest and strongest six-axis, modular construction, electric servo-driven family of robots designed for a variety of manufacturing and systems processes.

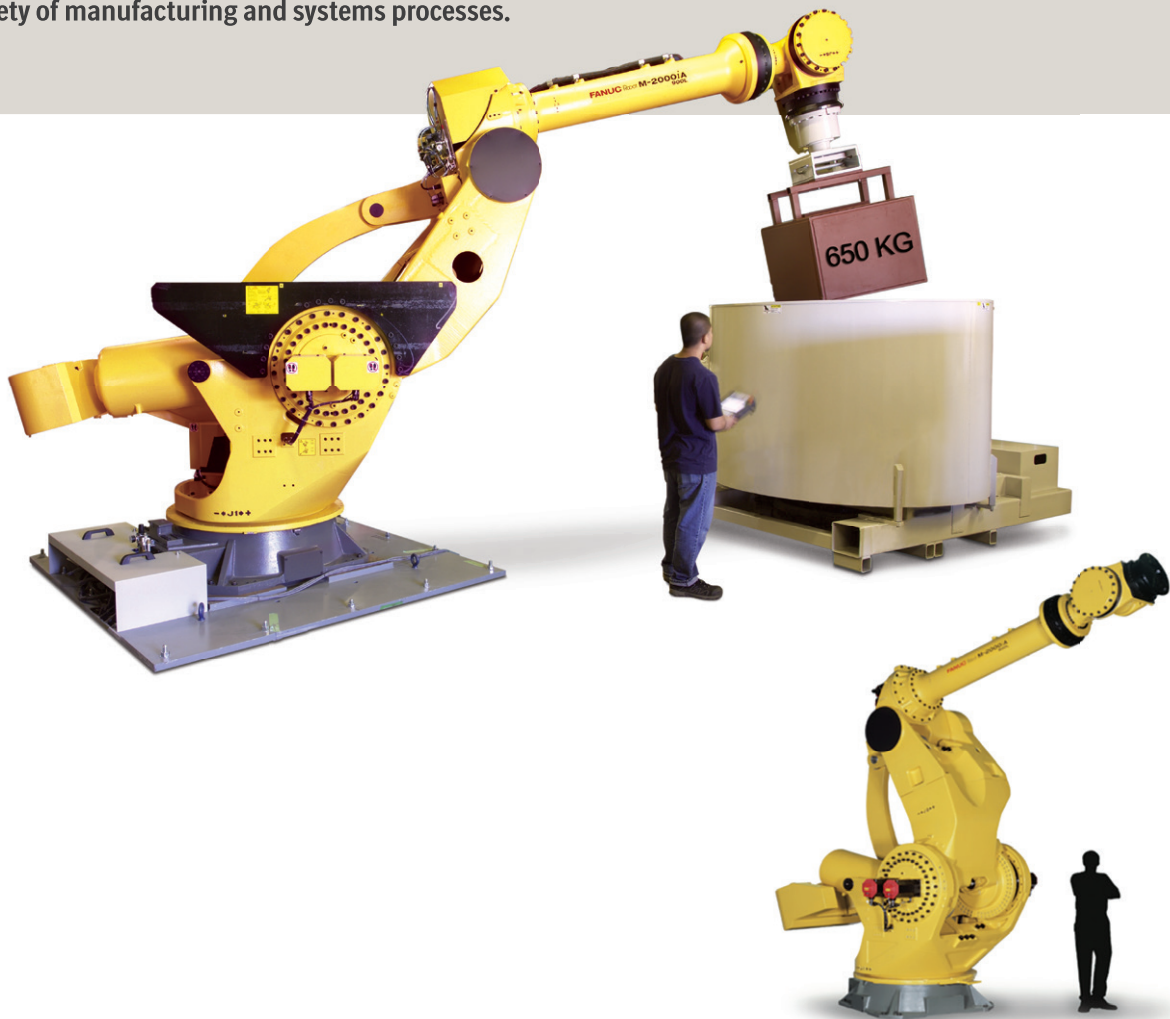

SPECIFICATIONS		
ITEMS	M-2000iA/1200	M-2000iA/900L
Axes	6	6
Payload - Wrist (kg)	1200	900
- J3 Arm (kg)	50	50
- J2 Base (kg)	550	550
Reach (mm)	3734	4638
Repeatability (mm)	±0.3	±0.5
Motion range (degrees)	J1	330 (±165)
	J2	160 (+100/-60)
	J3	165 (+35/-130)
	J4	720 (+/-360)
	J5	240 (+/-120)
	J6	720 (+/-360)
Motion speed (degrees/s)	J1	45
	J2	30
	J3	30
	J4	50
	J5	50
	J6	70
Wrist moments N-m (kgf-m)	J4	14700(1500)
	J5	14700(1500)
	J6	4900(500)
Wrist load inertia (kg-m ²)	J4	2989
	J5	2989
	J6	2195
Mechanical brakes	All Axes	All Axes
Mechanical weight (kg)	8600	9600
Mounting method ⁽¹⁾	Floor	
Installation environment	0 to 45	
Ambient Temperature (°C)	0 to 45	
Humidity	Normally: 75% or less Short term (within a month): 95% or less No condensation (No dew or frost)	
Vibration (m/s ²)	4.9 or less (0.5G or less)	
IP Rating(s)	Wrist IP67, rest IP54	

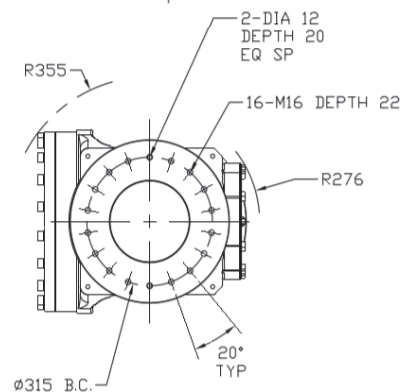
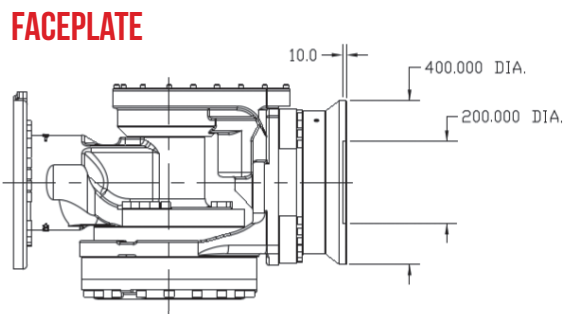
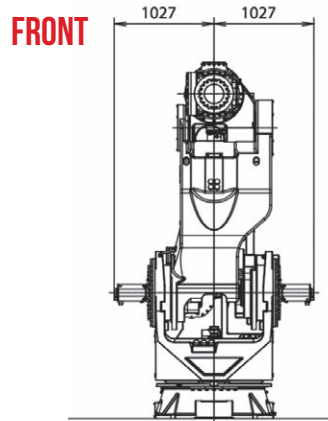
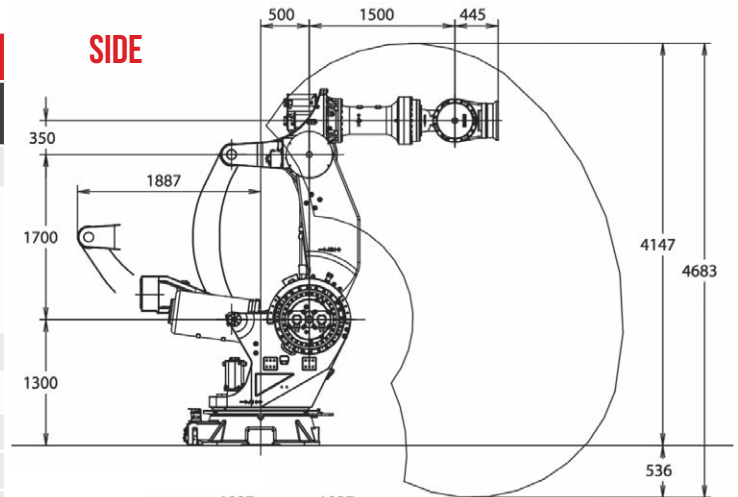

The background of the image is a light gray architectural floor plan. It features various geometric shapes, lines, and symbols representing a building's layout, including rooms, corridors, and structural elements. Overlaid on this background is the text 'SHELL ROOM PRODUCTS' in a large, bold, red, sans-serif font. The text is arranged in four lines: 'SHELL' on the first line, 'ROOM' on the second, 'PRO' on the third, and 'DUCTS' on the fourth. The red color of the text contrasts sharply with the light gray background.

**SHELL
ROOM
PRO
DUCTS**

CERAMIC SHELL PRODUCTION

PERFORMANCE IN THE SHELL ROOM

SHELL-O-MATIC OFFERS ALL THE NECESSARY ELEMENTS FOR A TOTALLY INTEGRATED SHELL PRODUCTION SYSTEM:

- » Robots
- » Slurry mixing tanks
- » Sanding devices
- » Conveying and drying systems
- » Loading/unloading devices
- » Computer-supervised manufacturing

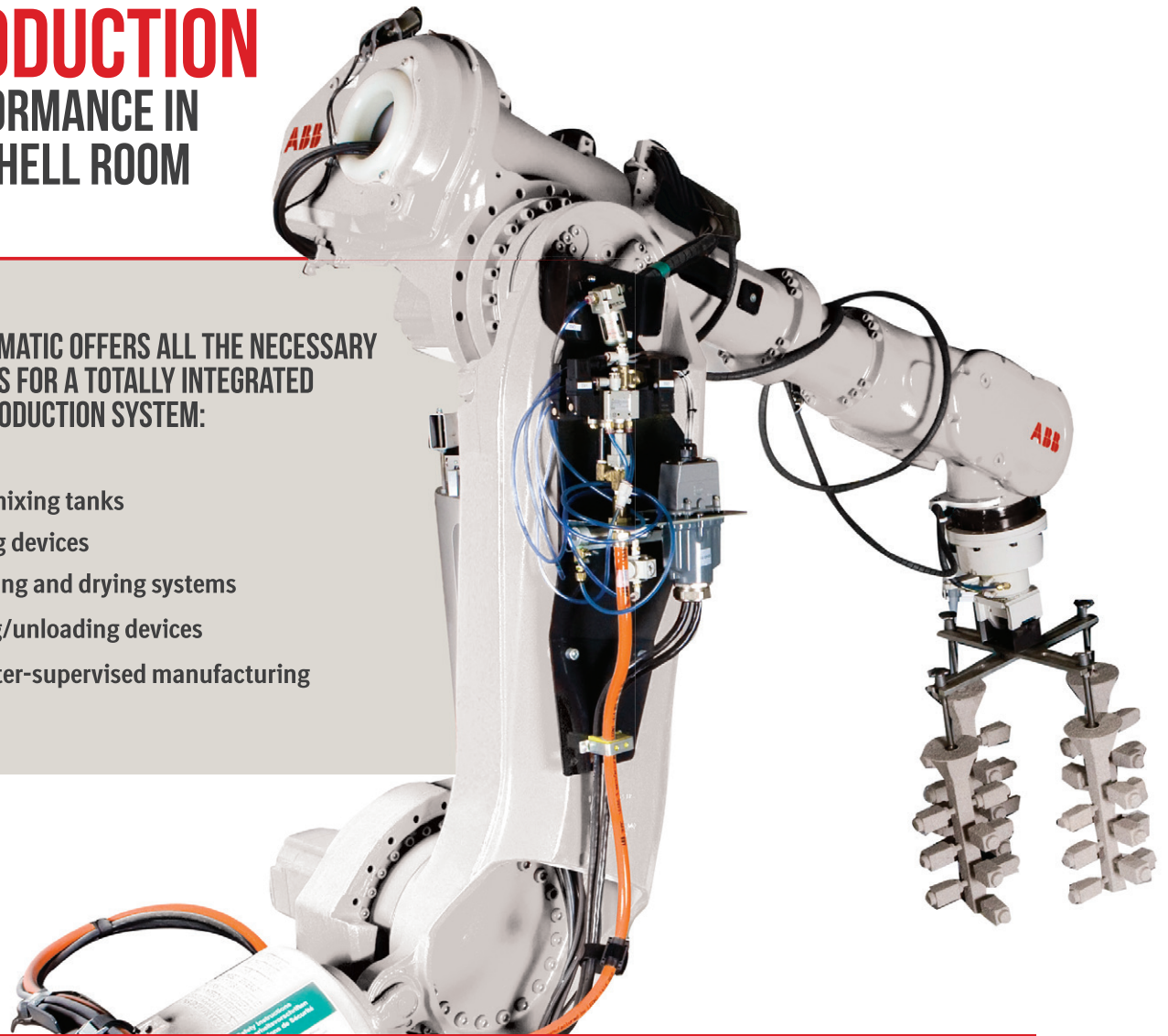

TYPICAL COMPLEX CASTING PRODUCED ON SHELL-O-MATIC EQUIPMENT



SHELL-O-MATIC

EXAMPLE OF A ROBOT BUILDING SYSTEM

The 6 axis articulated robots are offered with a range of load capacities and physical “reach”, depending on the application. Careful consideration must be given to the torque “T” so that the robot’s wrist can resist the effect of load and distance.

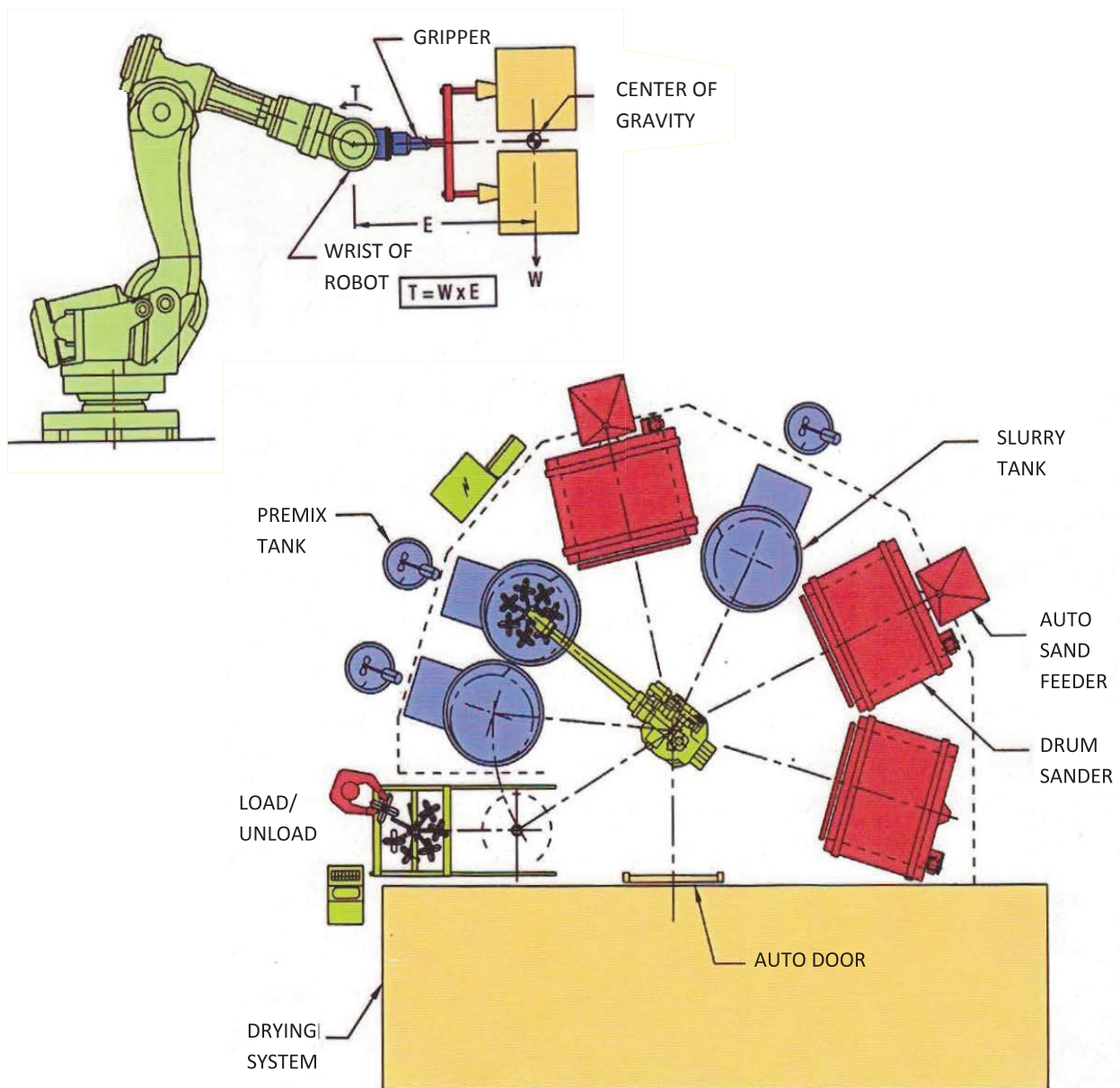

SYSTEM WITH 6 AXIS ROBOTS

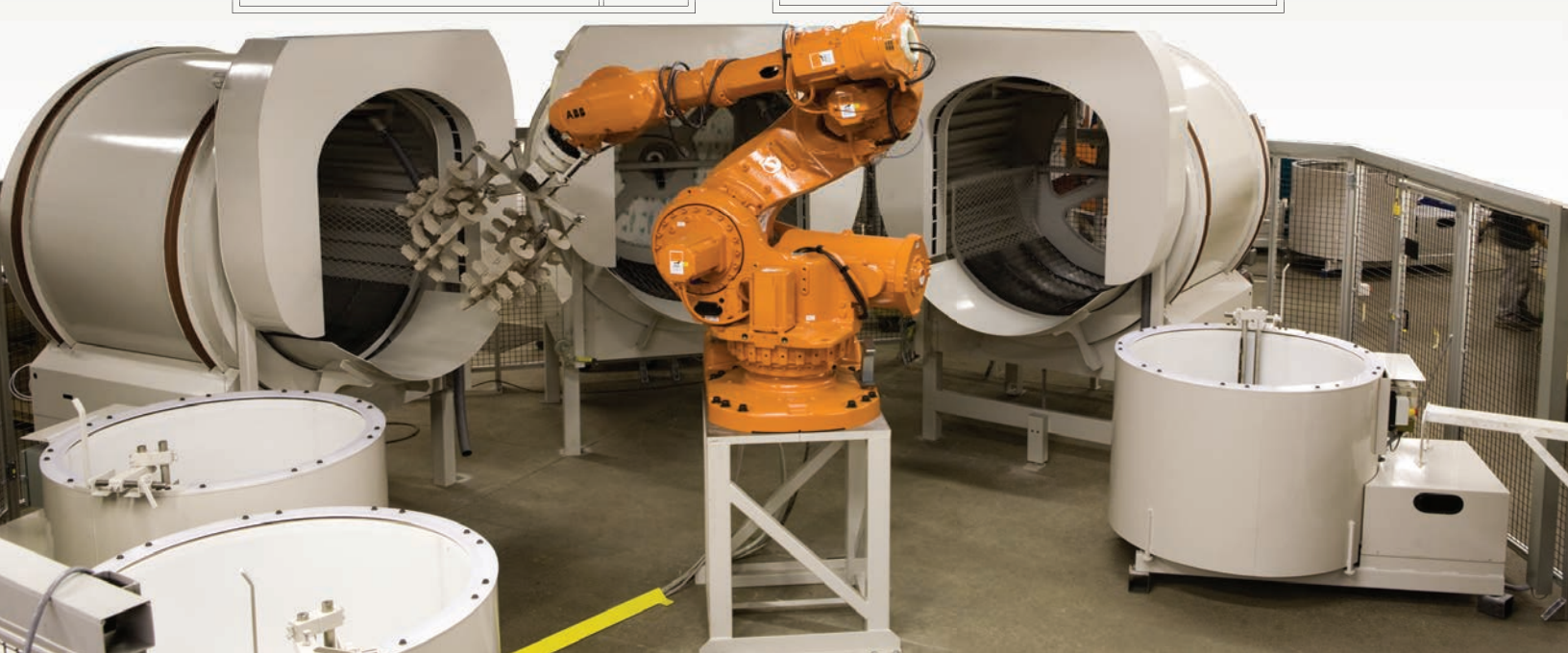
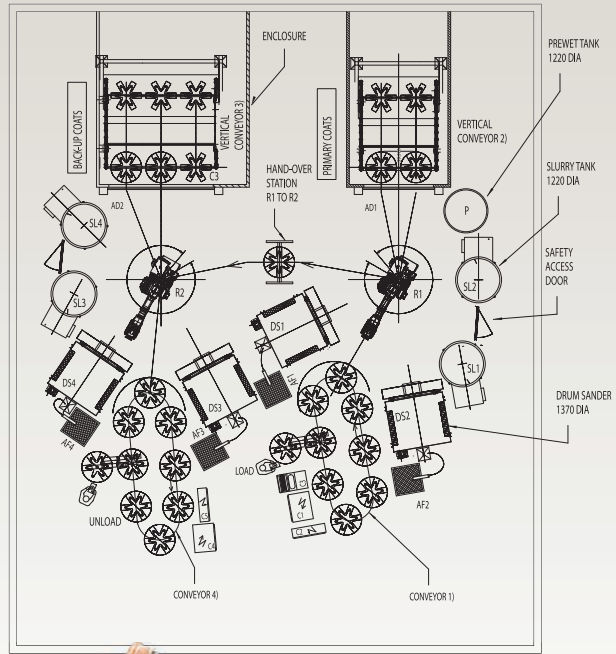
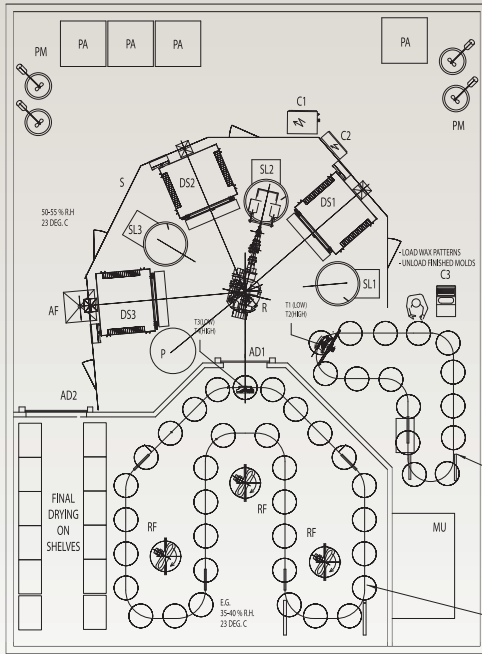

SYSTEM WITH A 7TH AXIS TRAVERSE MODULE

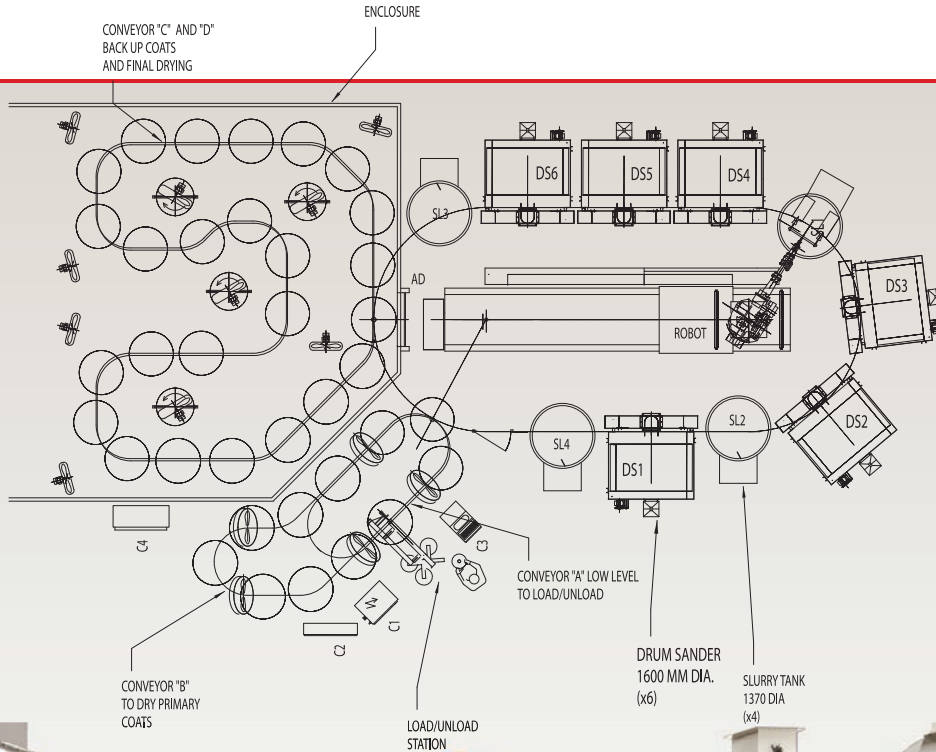

SHELL MANAGEMENT SUPERVISORY SYSTEM



DESCRIPTION

At loading point: Using a barcode scanner, the operator will enter the part number/recipe at the mini console when a cluster is loaded into the system.

Supervisory Computer: Will automatically select the proper program for a certain part which appears at the pickup point of the conveyor transfer station. If the part is not yet dry or if an empty hanger is there, the computer will index the conveyor at high speed to the next hanger ready to be dipped.

The recipe is the manufacturing instruction on how to build a ceramic shell for a certain part. The system can be configured for single or multiple robots and conveyor lines.

At unloading point: When a hanger with finished dipped molds appears at the unloading point, a light will flash. Once removed from the conveyor, the operator presses the acknowledgement button to erase the parts from the computer. At that moment a dipping report is generated.

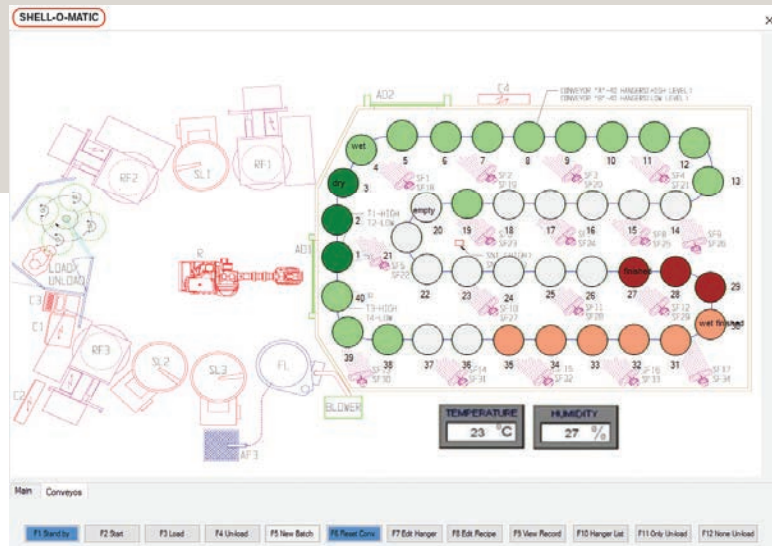
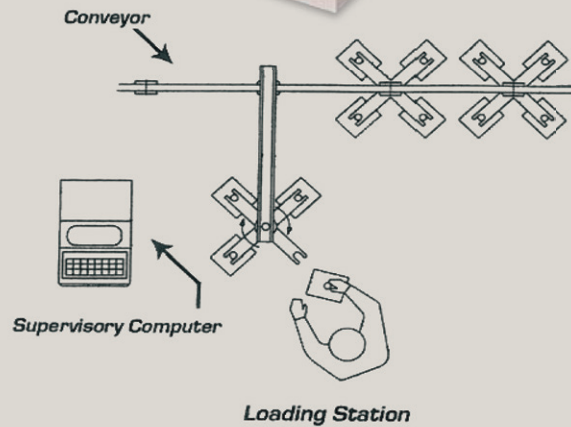

CERAMIC SHELL PRODUCTION EQUIPMENT

FROM SINGLE UNITS TO COMPLETELY ENGINEERED PROJECTS

ROBOTS

AC brushless servo technology

Load capacities

- » 60 kg (140 lbs)
- » 100 kg (250 lbs)
- » 200 kg (450 lbs)
- » 360 kg (800 lbs)
- » 675 kg (1500 lbs)

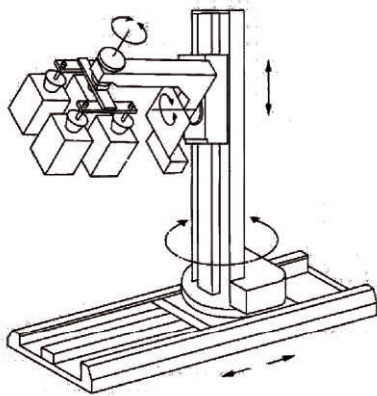

MOLD TRACKING SYSTEM

BAR CODING of part number helps you avoid operator errors.



MINI CONSOLE contains supervisory computer and printer. Enclosure is dust protected and ventilated.

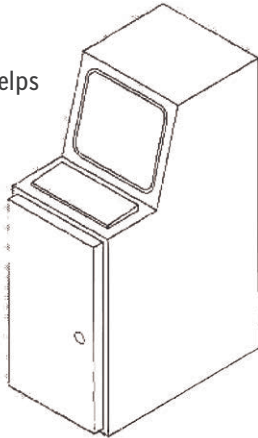

SLURRY LEVEL SENSING SYSTEM

The robot follows the slurry level and coats every mold to the same height.

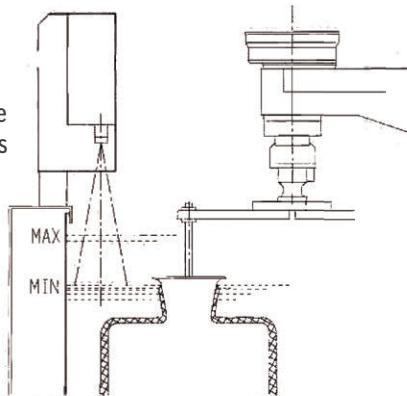

JOY STICK

With this option, you can add manual operations in the middle of an otherwise automatic robot program.

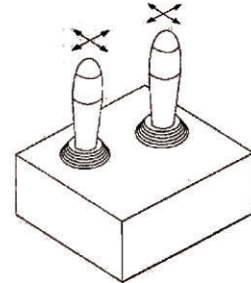

SLURRY MIXING TANKS

Tank Ø

- | | |
|---------------|----------------|
| 610 mm (24") | 1370 mm (54") |
| 760 mm (30") | 1525 mm (60") |
| 812 mm (32") | 1700 mm (68") |
| 915 mm (36") | 1905 mm (75") |
| 1040 mm (41") | 2232 mm (88") |
| 1090 mm (43") | 2540 mm (100") |
| 1220 mm (48") | |

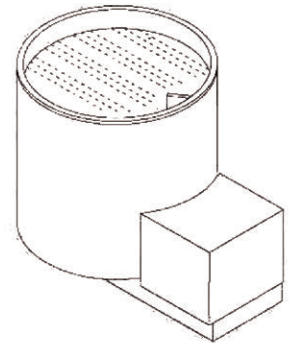

PART DIPPING REPORT

PART #: 12345 ON HANGER #: 35

COAT	PROGRAM #	START DIPPING TIME	TEMP. (C)	REL. HUMIDITY (%)	ACTUAL DRYING TIME (MIN)
1	9	11:11 23-10	25	45	147
2	11	13:38 23-10	25	45	153
3	3	16:11 23-10	25"	46	145
4	3	18:36 23-10	25	45	176
5	7	21:32 23-10	25	45	165
6	90	00:17 23-10	25	45	212

When a mold or a cluster of molds has received all coats and has been removed from the coating system, a report is automatically printed showing all the vital parameters of the shell building process.

RAINFALL SANDER

RAINFALL

Model	Sand rain Ø
100	760 mm (30")
140	960 mm (38")
250	1220 mm (48")
350	1470 mm (58")
550	1670 mm (64")
600	1980 mm (78")

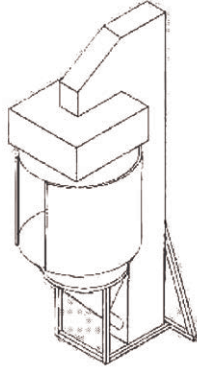

FLUIDIZED BED AND HIGH PRESSURE BLOWER

Fluidizer Ø

570 mm (22.5")
760 mm (30")
915 mm (36")
1015 mm (40")
1145 mm (45")
1270 mm (50")
1350 mm (53")
1525 mm (60")

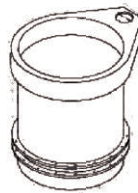

SAND FEEDING SYSTEMS

For rainfall sanders and fluidized beds. Floor based or mezzanine based. Combined with level sensor allows fully automatic operation.

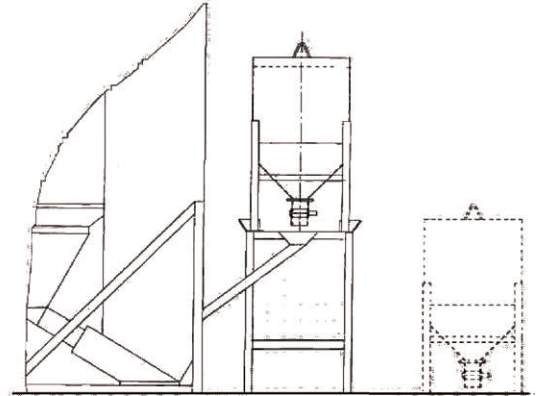

Also available:
Combined rainfall/
fluidizer

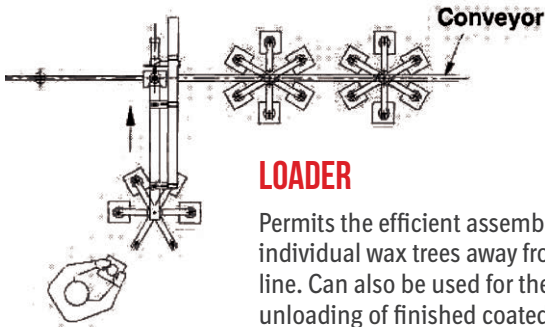

LOADER

Permits the efficient assembly of clusters from individual wax trees away from the conveyor line. Can also be used for the unloading of finished coated parts.

TRANSFER SHUTTLE

This linear handling device automatically moves molds from one conveyor to another.

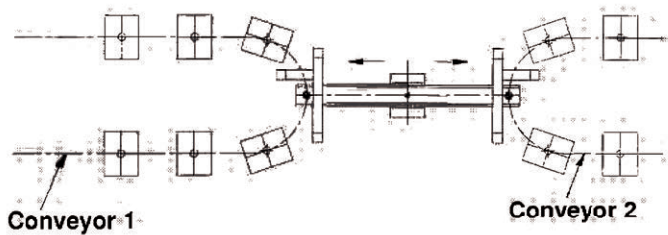

AUTO SLIDING DOOR

(Horizontal)

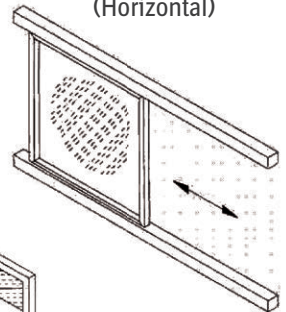

AUTO ROLLING DOOR

(Vertical)

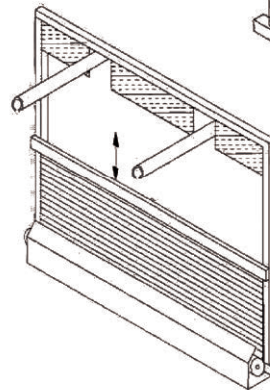

ELEMENTS AND SYSTEMS for drying rooms and tunnels. Control relative humidity, temperature and air speed.

SLURRY PREMIXING AND FEEDING

Floor based and mezzanine based systems.

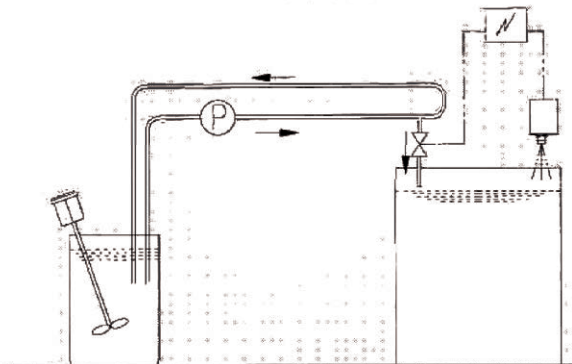

SLURRY MIXING TANKS

HEAVY DUTY, BELT DRIVEN MODEL

SINCE THE CREATION OF SHELL-O-MATIC, WE HAVE BUILT NEARLY 1000 SLURRY TANKS SO WE KNOW THERE IS MUCH MORE TO IT THAN A SIMPLE ROTATING DRUM WITH A PADDLE.

First, we pay attention to providing our customer with rugged and reliable driving mechanisms to ensure their tanks never stop. Second, we know that slurry material is expensive and probably the most important and sensitive component of the shell building system, so we provide you with all available options to measure, control and maintain the slurry quality.



This includes:

- » Level sensing and control of the robot to maintain constant dipping depth
- » Rotating speed adjustment
- » Real time viscosity sensing
- » Temperature sensing and control through a water-cooled paddle
- » Automatic cover that opens only when parts need to be dipped
- » Vacuum slurry tanks if needed

To ensure ease of cleaning we can also provide a variety of plastic covers and liners, including one-piece plastic liners for the tank interior. Furthermore, all wetted parts of the tank are made of high-quality stainless steel.

We can also provide turntables that can hold many tanks and position the one needed for the robot area, thus allowing a smaller envelope robot to access a plurality of tanks. If you need to move the tank around, we can build it on an air cushion, making it easy for an operator to displace it.

**As per customer's request, special diameters and tank depths can be supplied

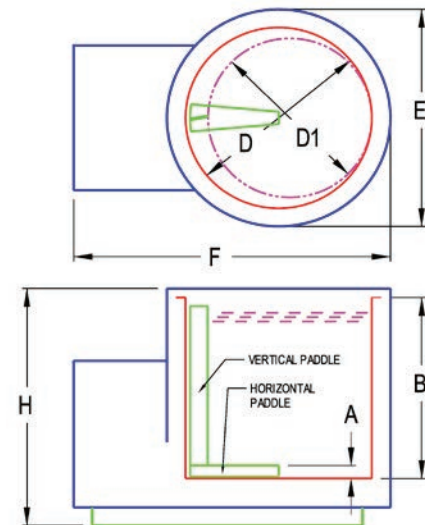

TANK SIZE D	D1	A	B	E	F	H	SLURRY VOLUME	
							LITER	US GAL
36" 915 mm	31" 785 mm	3" 75 mm	33.12" 840 mm	40" 1016 mm	58" 1475 mm	44" 1118 mm	540	142
41" 1040 mm	36" 915 mm	3" 75 mm	33.12" 840 mm	45" 1140 mm	63" 1600 mm	44" 1118 mm	700	185
43" 1090 mm	38" 965 mm	3" 75 mm	33.12" 840 mm	46" 1170 mm	63" 1600 mm	44" 1118 mm	772	204
48"-L 1220 mm	42" 1067 mm	3" 75 mm	33.6" 854 mm	51" 1295 mm	63" 1600 mm	44" 1118 mm	960	254
48"-H 1220 mm	42" 1067 mm	3" 75 mm	37.4" 950 mm	51" 1295 mm	75" 1905 mm	44" 1118 mm	1070	281
54"-L 1370 mm	48" 1220 mm	3" 75 mm	31.5" 800 mm	57" 1448 mm	78" 1980 mm	44" 1118 mm	1111	293
54"-H 1370 mm	48" 1220 mm	3" 75 mm	36" 915 mm	57" 1448 mm	78" 1980 mm	49.2" 1250 mm	1295	342
60"-L 1525 mm	54" 1370 mm	3" 75 mm	31.5" 800 mm	63" 1600 mm	81" 2060 mm	44" 1118 mm	1370	361
60"-H 1525 mm	54" 1370 mm	3" 75 mm	40.2" 1021 mm	63" 1600 mm	81" 2060 mm	49.2" 1250 mm	1597	422
62"-L 1575 mm	56" 1425 mm	3" 75 mm	34" 865 mm	66" 1675 mm	98" 2475 mm	46" 1175 mm	1529	402
62"-H 1575 mm	56" 1425 mm	3" 75 mm	47" 1195 mm	66" 1675 mm	98" 2475 mm	59" 1500 mm	2172	572
67" 1700 mm	60" 1525 mm	3.5" 90 mm	42.5" 1080 mm	71" 1803 mm	102" 2590 mm	59.25" 1504 mm	2160	568
72" 1830 mm	64" 1625 mm	7" 180 mm	52" 1320 mm	80" 2030 mm	109" 2770 mm	74.5" 1890 mm	3274	862
75"-L 1905 mm	66.5" 1670 mm	4" 100 mm	48.5" 1232 mm	81" 2057 mm	105" 2667 mm	54.75" 1390 mm	2700	710
75"-H 1905 mm	66.5" 1670 mm	4" 100 mm	60" 1525 mm	81" 2057 mm	105" 2667 mm	71.8" 1825 mm	3700	975
88" 2235 mm			**	95" 2415 mm	125" 3175 mm			
100" 2540 mm			**	106" 2695 mm	138" 3505 mm			

SLURRY MIXING TANKS DIRECT DRIVEN MODEL

STANDARD FEATURES

- » Removable, L-shaped paddle
- » On/off switch
- » Overload protection

Options

- » Variable speed
- » Slurry level sensing
- » Remote start/stop
- » Automatic cover
- » Water cooling
- » Plastic liner
- » Temperature controls
- » Full plastic tank
- » Zero speed detection (alarm)

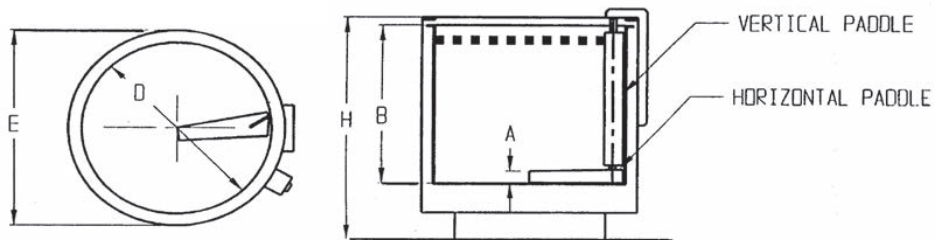

TANK SIZE D	E	A	B	H	SLURRY VOLUME	
					LITER	US GAL
24" 610mm	28" 710mm	2.5" 64mm	27" 685mm	37.75" 960mm	185	49
30" 760mm	34" 870mm	2.75" 70mm	28" 710mm	38.75" 985mm	300	78
32" 810mm	36" 910mm	2.75" 70mm	29" 735mm	40" 1015mm	353	93
36"-L 915mm	40" 1016mm	3" 75 mm	25" 635mm	38.75" 985mm	380	100
36"-H 915mm	40" 1016mm	3" 75 mm	30" 762mm	43.5" 1104mm	465	122
47.5" 1200mm	52.7" 1340mm	3.8" 96mm	41.6" 1056mm	57.5" 1460mm	1085	285

SLURRY MIXING TANKS OPTIONS/VARIANTS

VERY LARGE TANK

88"-2235 mm dia.

Mobile unit with on-board drive



**VACUUM
SLURRY TANK**

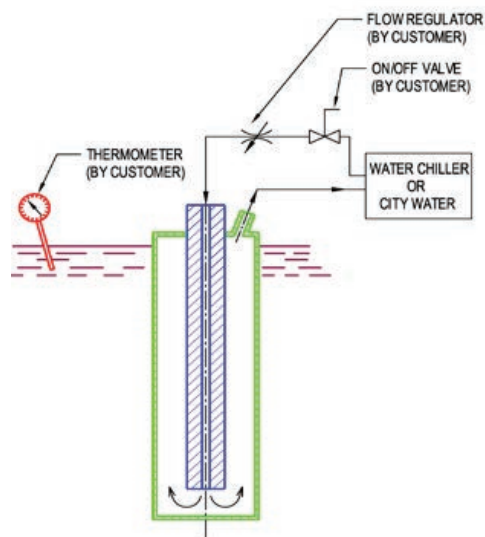

**WATER COOLING
MANUALLY CONTROLLED**

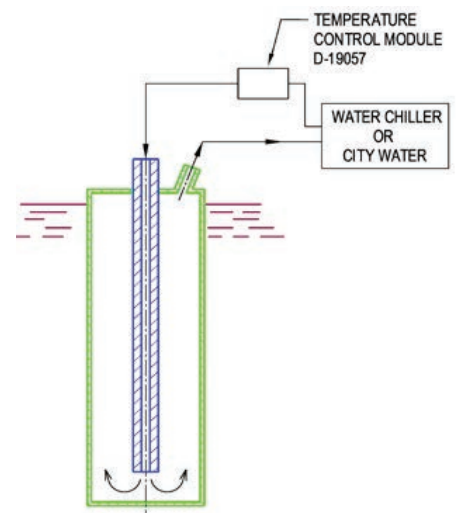

**WATER COOLING
AUTOMATICALLY CONTROLLED**

SLURRY MIXING TANKS OPTIONS/VARIANTS

VISCOMETER

The AST-100IPRI Viscometer is inserted into the slurry and outputs continuous measurement of viscosity and temperature. The instrument enables automatic viscosity control and improved quality assurance over cup method.

Benefits:

- » Correlates with lab viscometer and cup measurement
- » Enables continuous logging of viscosity and temperature
- » Alarms for “off-spec” slurry condition
- » Improves stucco coverage and optimizes drying time
- » Reduces cracking, excess metal, burn in and penetration
- » Minimizes operator involvement

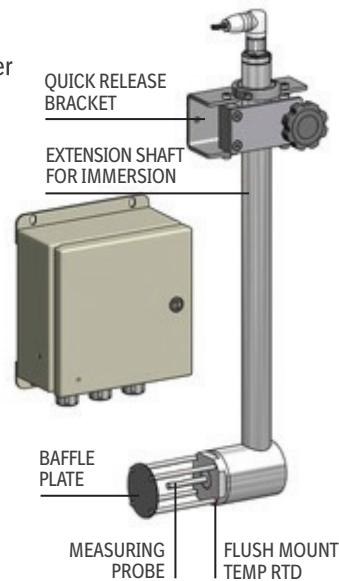

Features:

- » 316SS construction with baffle plate for abrasion protection
- » Easy cleanable design with no moving parts
- » Internal RTD eliminates slurry build up
- » Viscosity & temperature outputs as 4-20mA, RS-485 & RS-232
- » Fully tested for future QC checks

Options:

- » AST-310SY-420 controller for closed loop viscosity control
- » Quick release bracket for inspection and cleaning
- » Manual and wireless data logging options
- » 115VAC, 230VAC or 24vdc power input options

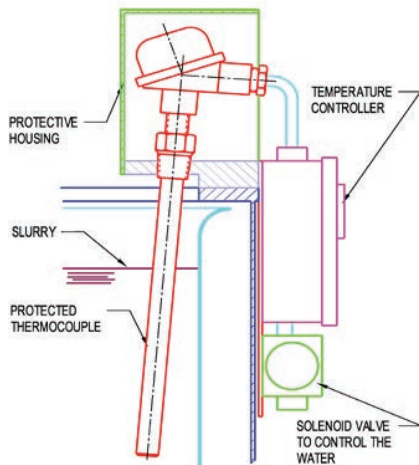

Water Cooling Control
Module D-19057

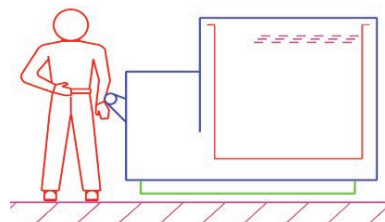

Mobile Slurry Tank
On Air Cushions

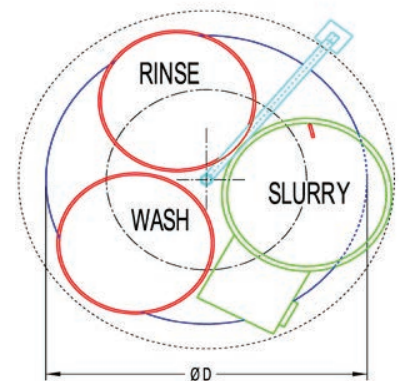

Turntable, Powered
» Size 1 - 90”
» Size 2 - 100”

AUTOMATIC SLURRY LEVEL SENSING

The robot follows the slurry level and maintains a constant shell dimension "A".

When the minimum slurry level "Q" is reached, the robot will stop at the end of the cycle and give an alarm signal.

The operator then adds slurry to max. level (using a pump, by gravity or manually).

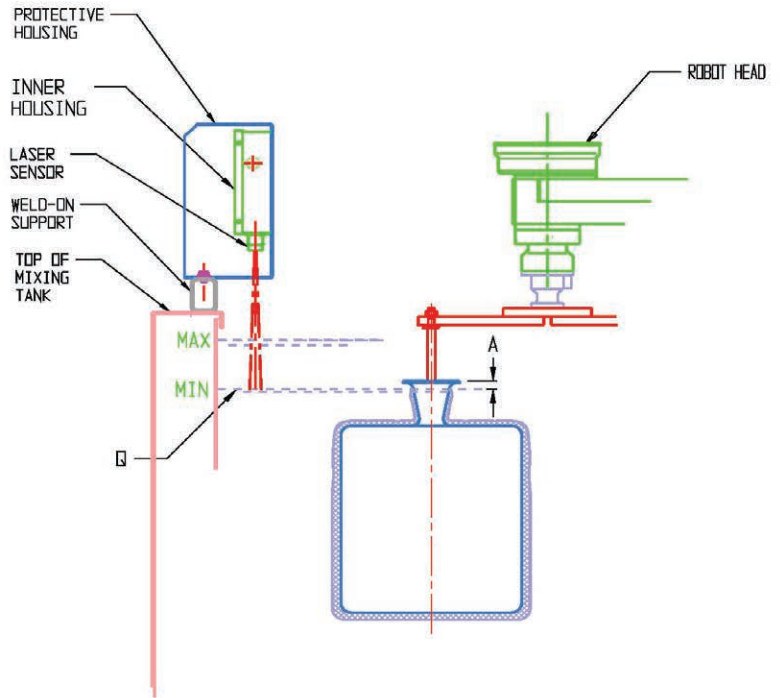
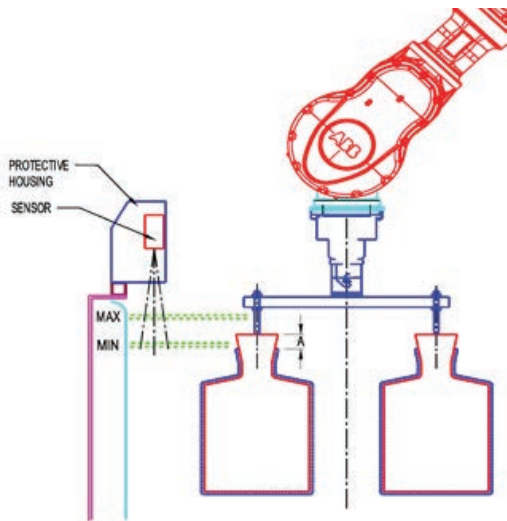

SLURRY LEVEL SENSOR



SLURRY TRANSFER PUMP

SLURRY PREMIX TANK ROTATING TANK MODEL

Shell-O-Matic premixing tanks are available in a rotating and non-rotating version (water drop shape).

The wetted parts of these tanks are all made of high-quality stainless steel to ensure tank longevity and to prevent foreign material contamination. Depending on your needs, we can offer an air-driven or electric propeller mixer.

If you need to save time on the slurry preparation while making sure of a proper ingredient suspension, we can also propose a high-shear mixer. This new mixing technique reduces the mixing time to a minimum. Just give us your slurry parameter requirements and we will offer you a premixing tank you can depend on.

We can also provide slurry transfer pumps to facilitate the replenishment of your slurry tanks.

- » All wetted parts are made of high-quality stainless steel.
- » Various mixers are available to match your process or save on your preparation time.
- » Robust and reliable tanks made to the highest standards.

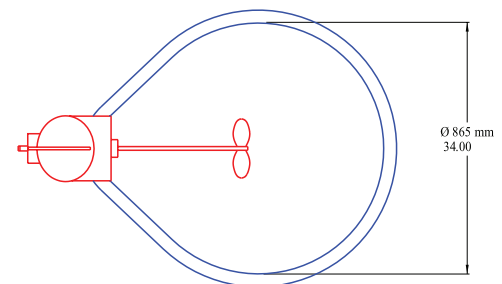
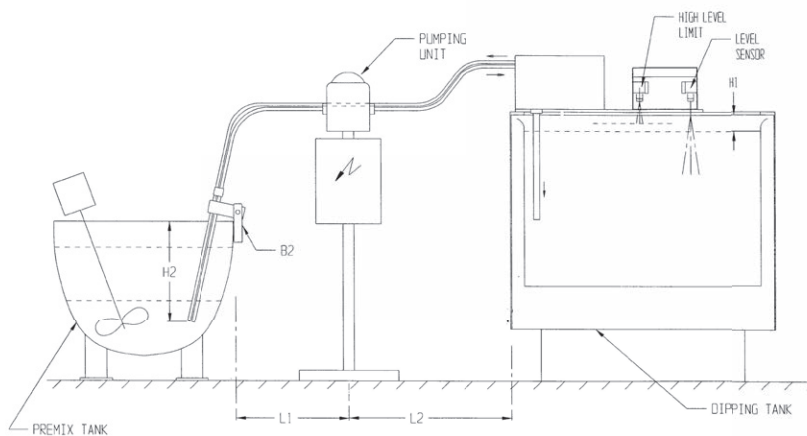
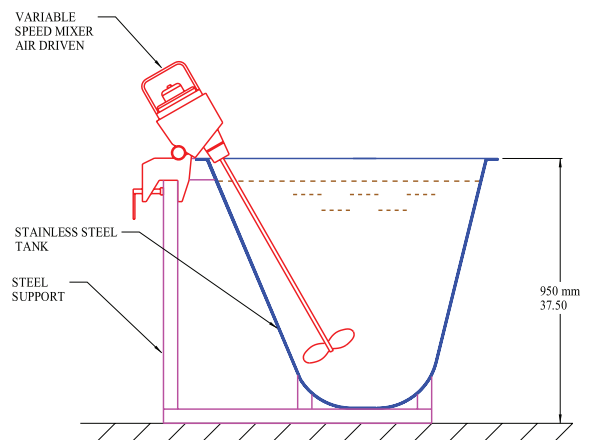

LARGE SCALE SLURRY TANKS

BECAUSE SHELL-O-MATIC'S ORIGINAL ROBOT PRODUCT LINE ALWAYS INCLUDED A 680 KG CAPACITY ROBOT, WE NATURALLY DEVELOPED A SPECIALTY IN MAKING OVERSIZE EQUIPMENT.

So far our record is a 100"/2540 mm diameter slurry tank and a 83"/2100 mm drum sander. If you are dealing with heavy parts or plan on doing so, call a Shell-O-Matic specialist that will most likely have interesting solutions for you.

- » Shell-O-Matic can design custom slurry tanks to match oversize part requirements.
- » Rainfall sander and drum sander design can be sized to match your needs.
- » We have the expertise to ship and install oversize equipment around the world.



DRUMSANDERS

THERE ARE MANY SMALL DETAILS THAT MAKE OUR DRUM SANDERS DIFFERENT FROM OUR COMPETITION, STARTING WITH THE FACT THAT WE HAVE THE EXPERTISE TO TWEAK IT TO YOUR NEEDS.

Give us your sand specs and rain flow requirements and we will tailor the sand rain to your spec, making sure you can adjust the rain flow within a desired range.

Furthermore, we can integrate your sander with automatic sand feeding system so you never run out of sand, thus improving your productivity. We can also offer sand exchange systems, making it easy in your process to switch from one sand type to another. Finally, since most sands used in the investment casting industry create toxic dust, we engineered a dust collection system tested to make sure your workers are safe.

Standard features

- » Variable speed drive
- » Local start/stop switch
- » Remote start/stop
- » Manual sand feeding

Optional features

- » Dust collection ring
- » Sand feeding hopper
- » Pneumatic sand feeding
- » Sand weighing system with load cell
- » Rear view window
- » Sand changeover unit
(use one drumsander with several sands)



Rear view



Drum sander for manual operation

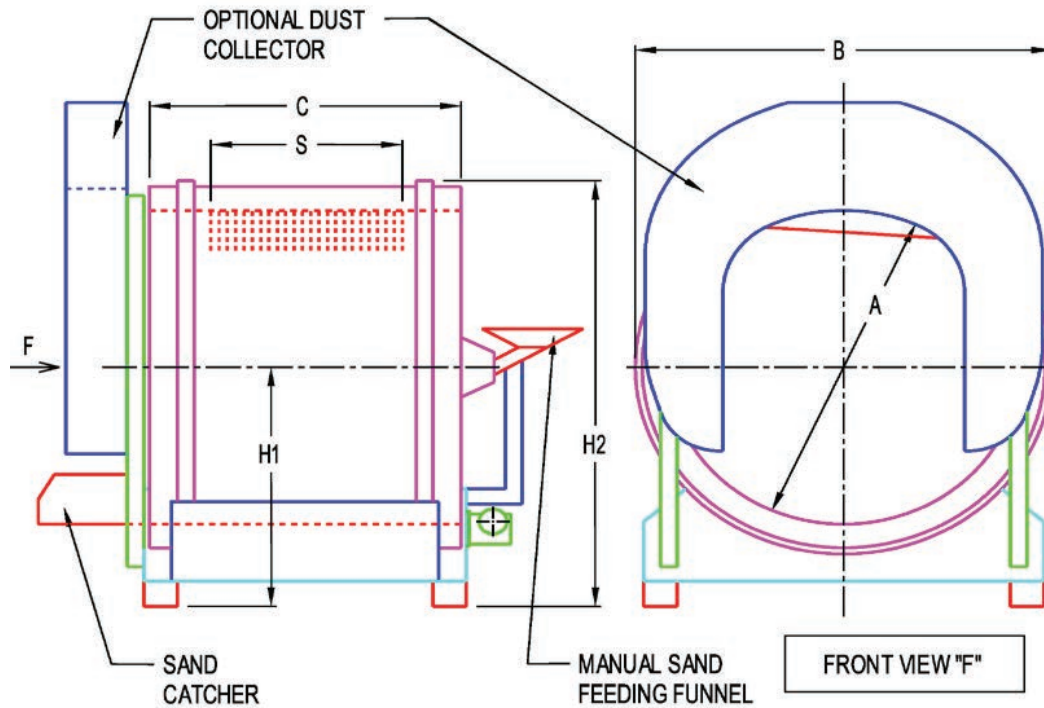

SIZE INSIDE DIA. A	48.0" - 1220 MM	54.0" - 1370 MM	63.0" - 1600 MM	72.0" - 1828 MM	83.0" - 2108 MM
B	64.5" - 1640 mm	69" - 1750 mm	79.5" - 2020 mm	86.0" - 2185 mm	100.75" - 2560 mm
S (Sand Rain)	36.0" - 915 mm	39.0" - 990 mm	42.0" - 1067 mm	50.0" - 1270 mm	57.0" - 1450 mm
C	54.0" - 1370 mm	57.25" - 1455 mm	60.5" - 1540 mm	71.5" - 1815 mm	88.0" - 2185 mm
H1 (Minimum)	39.5" - 1005 mm	41.0" - 1040 mm	45.0" - 1143 mm	46.75" - 1190 mm	51.25" - 1302 mm
H2 (Minimum)	71.5" - 1815 mm	75.5" - 1920 mm	85.0" - 2160 mm	91.0" - 2315 mm	101.5" - 2580 mm

AUTOMATIC SAND FEEDING SYSTEM FOR DRUM SANDER

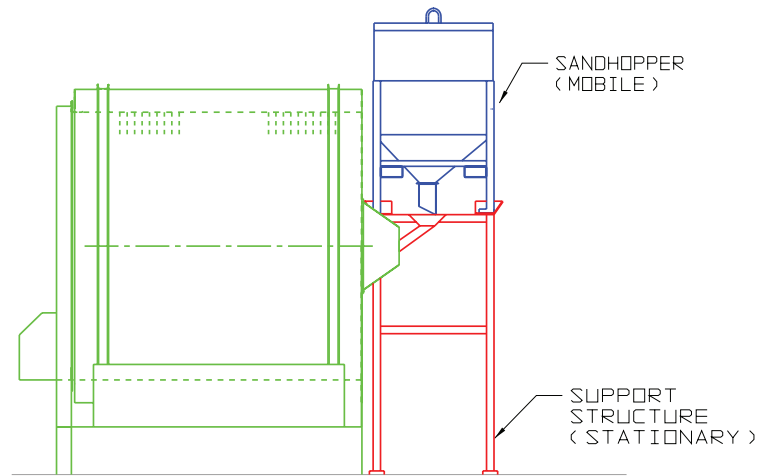

DRUMSANDER 38" DIA — 965 MM Ø FOR MANUAL OPERATION

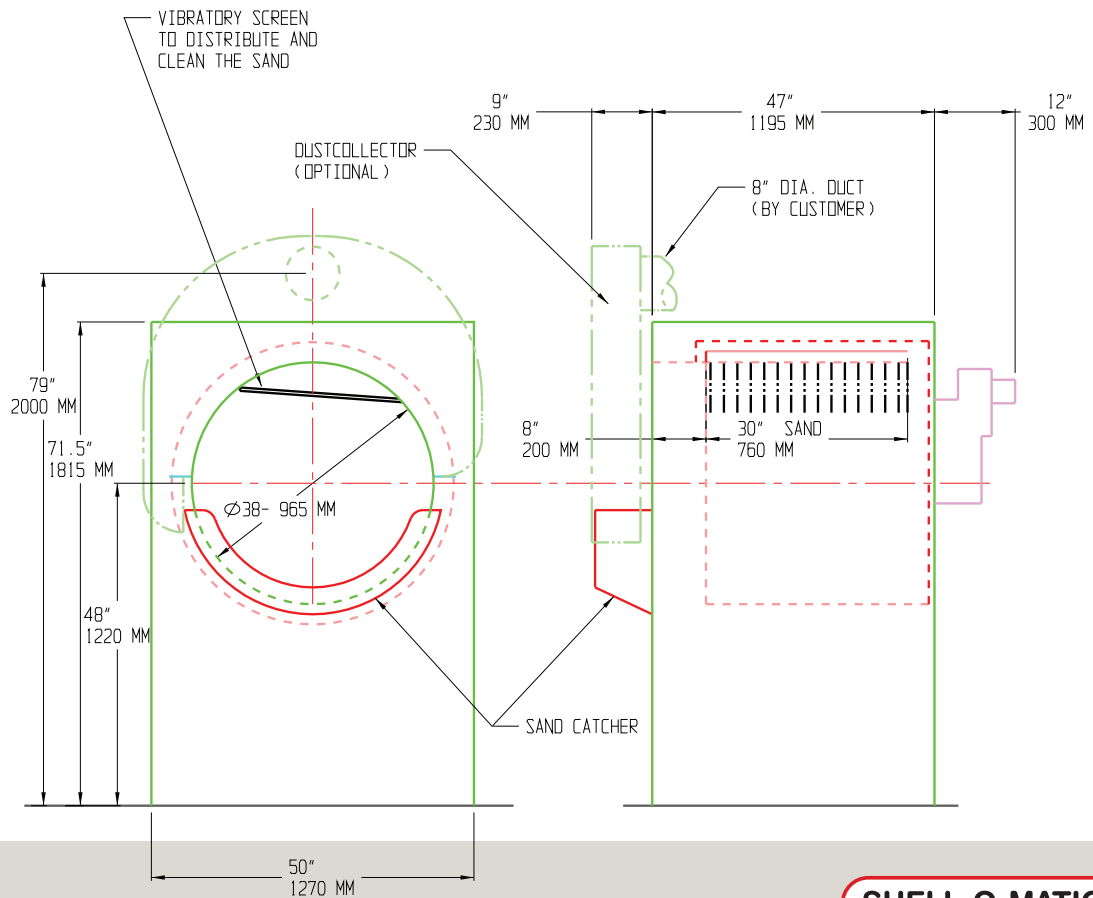

PNEUMATIC SAND FEEDER

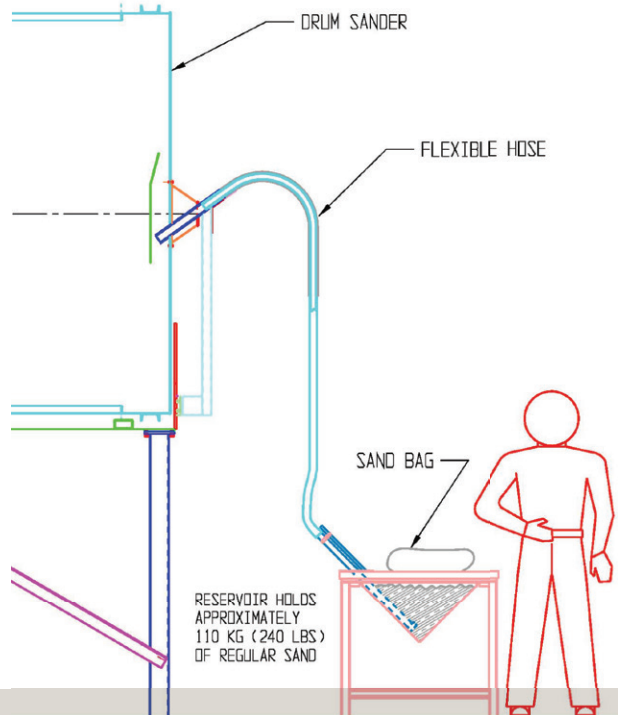

RAINFALL SANDER

APPLYING STUCCO THE EASY WAY

FEATURES

- » Dense and uniform sand distribution over a large area ensures fast stuccoing.
- » Rapid change-over from one stucco to another; fine or coarse sand.
- » Automatic, continuous sand cleaning is built-in.
- » Clamshell-type swing doors contain dust and sand during stuccoing operation.

The investment casting industry uses fluidized beds or rainfall sanders for the stuccoing of wax patterns.

In many cases it is advantageous to use a rainfall sander:

- » For delicate wax pattern structures which can break in a fluidized bed.
- » When the sand movement in a fluidized bed is too abrasive and thins or removes the ceramic slurry coats.

The previously available rainfall sanders, however, were characterized by several problems, such as:

- » Lean sand rain; slows production time.
- » Creation of additional dust, by using high velocity air systems to elevate the sand.
- » Change-over from one stucco to another is very time consuming or impossible.
- » Lack of an effective sand cleaning system.

SHELL-O-MATIC HAS DESIGNED A UNIT WHICH EFFECTIVELY RESOLVES THE ABOVE MENTIONED PROBLEMS AND LETS YOU USE ANY NUMBER AND GRADE OF SAND ON A SINGLE MACHINE.



COMBINATION,
RAINFALL/FLUIDIZER

VERTICAL RAINFALL SANDERS WITH RAPID SAND-CHANGE SYSTEM

- » Six sizes
- » Equipped with Rapid Sand Change System

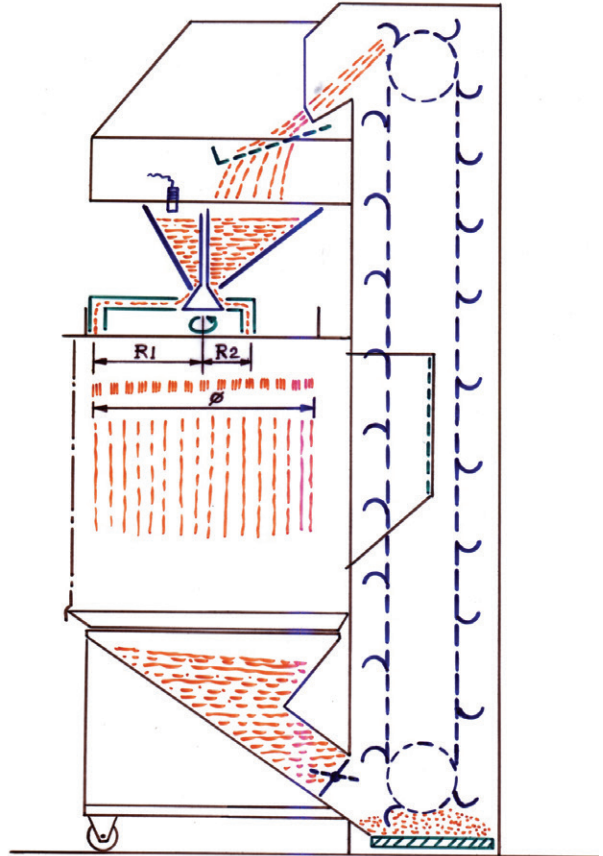

SANDER WITH VERTICAL DOORS



CHANGE-OVER FROM ONE STUCCO TO ANOTHER:

Switch sander on purging cycle and discharge stucco into receiving bin.

- » Disconnect (Quick Coupling) receiving bin from elevator and roll away.
- » Connect another receiving bin with other stucco.

POWER REQUIREMENTS:

APPROX. 2KW, 440, 3, 60 HZ.
550, 3, 60 HZ.
380, 3, 50 HZ.

COMPRESSED AIR 80 PSI, (6 BAR) ½ " LINE.

BLOWER AIR 0.5 PSI, 300 CFM
0,03 BAR, 500 NM³/H

	NO. 140		NO. 250		NO. 350	
A	38"	965 mm	48"	1220 mm	58"	1470 mm
B	49"	1255 mm	56"	1422 mm	63"	1600 mm
C	45.5"	1156 mm	51"	1295 mm	60"	1525 mm
H	13'6"	4115 mm	14'6"	4420 mm	16'5"	5000 mm
X	78"	1960 mm	84"	2134 mm	102"	2600 mm

ADDITIONAL FEATURES:

- » Three settings for sandflow, low - medium - high.
- » All logic for automatic operation with robot is built in.
- » Adaptor for dust collector is incorporated.
- » Low power consumption.

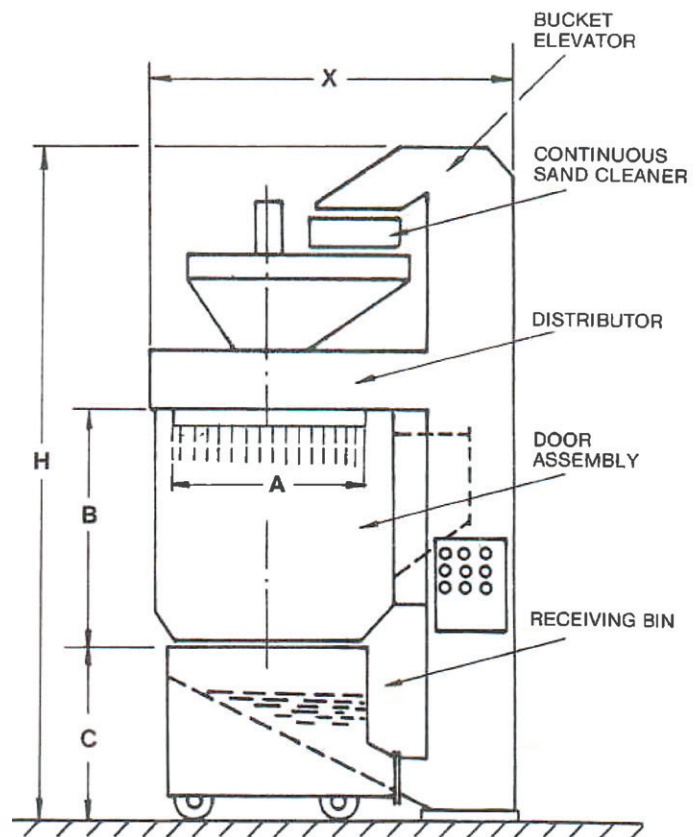

U.S. Patent No 4440806
Other Patents Pending

AUTOMATIC SAND FEEDING SYSTEM FOR RAINFALL SANDER, TYPE "FL"

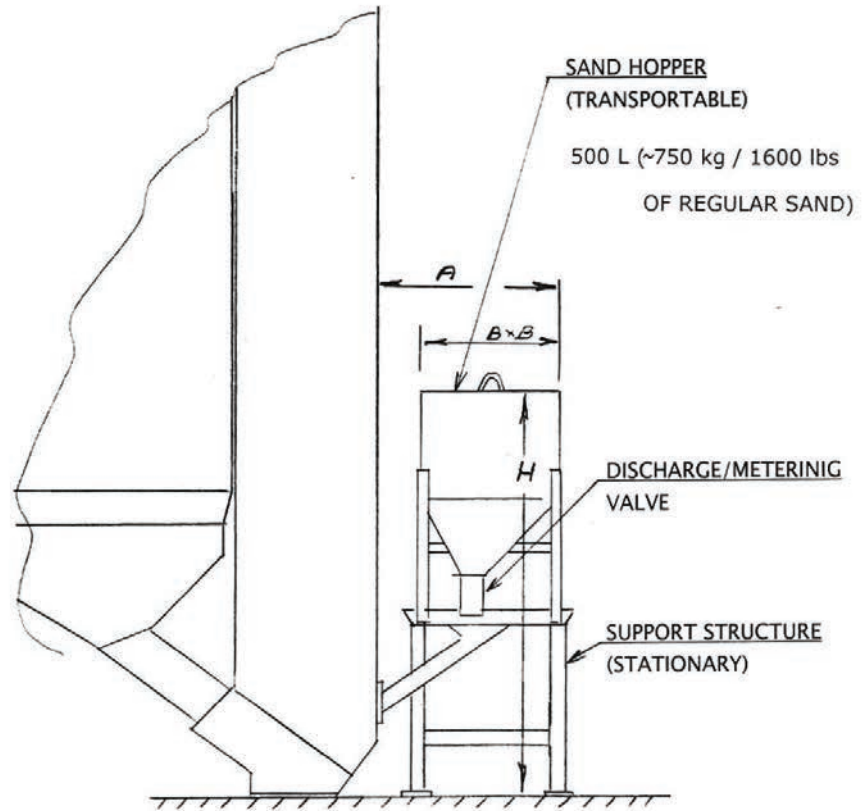

A = 48.5" - 1230mm
B x B = 32" x 32" - 815mm x 815mm
H = 101.5" - 2580mm

PNEUMATIC SAND FEEDING SYSTEM FOR RAINFALL SANDER

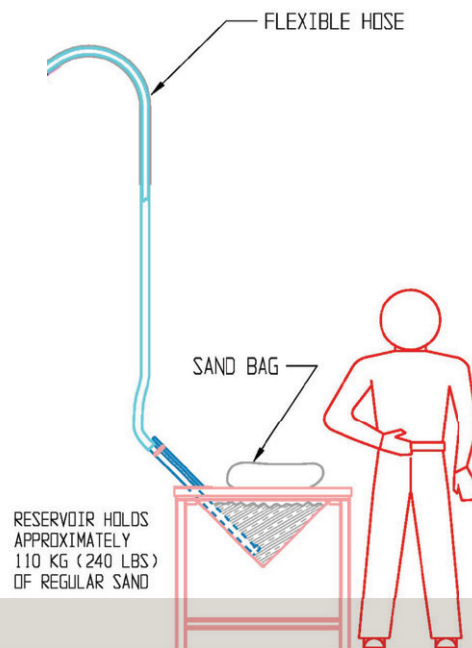

FLUIDIZED BEDS

FOR GENEROUS AND PRODUCTIVE STUCCO APPLICATION THAT REQUIRES A LOT OF SAND MOVEMENT A FLUIDIZER BED IS JUST WHAT YOU NEED.

When it is time to fluidize your sand, attention to detail is very important. At Shell-O-Matic we have a database of over 140 sand types of various granulometry with recorded proper and tested blower arrangement to insure perfect sand fluidization. Just give us your sand parameter and the chances are good that we have experience in making a fluidizer with similar if not identical sand.



We have also engineered a dust collection system to insure toxic sand dust does not contaminate your environment. So far, Shell-O-Matic has delivered over 330 fluidized beds. With such experience we have engineered every little detail, like using the right porous material at the bottom of the fluidizer to ensure a uniform sand fluidization.

- » Perfect sand fluidization all the times.
- » Dust collection system.
- » Turnkey package with properly sized fluidized bed and blowers for your application.

**Shown with optional
Dust-Collection Collar**

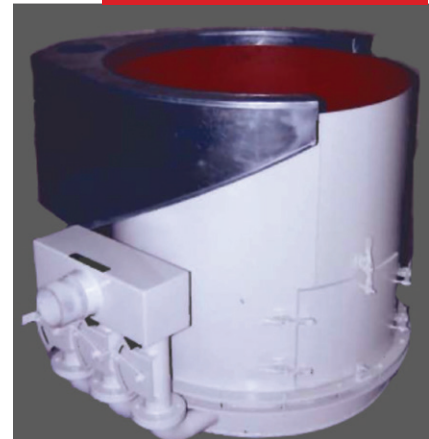

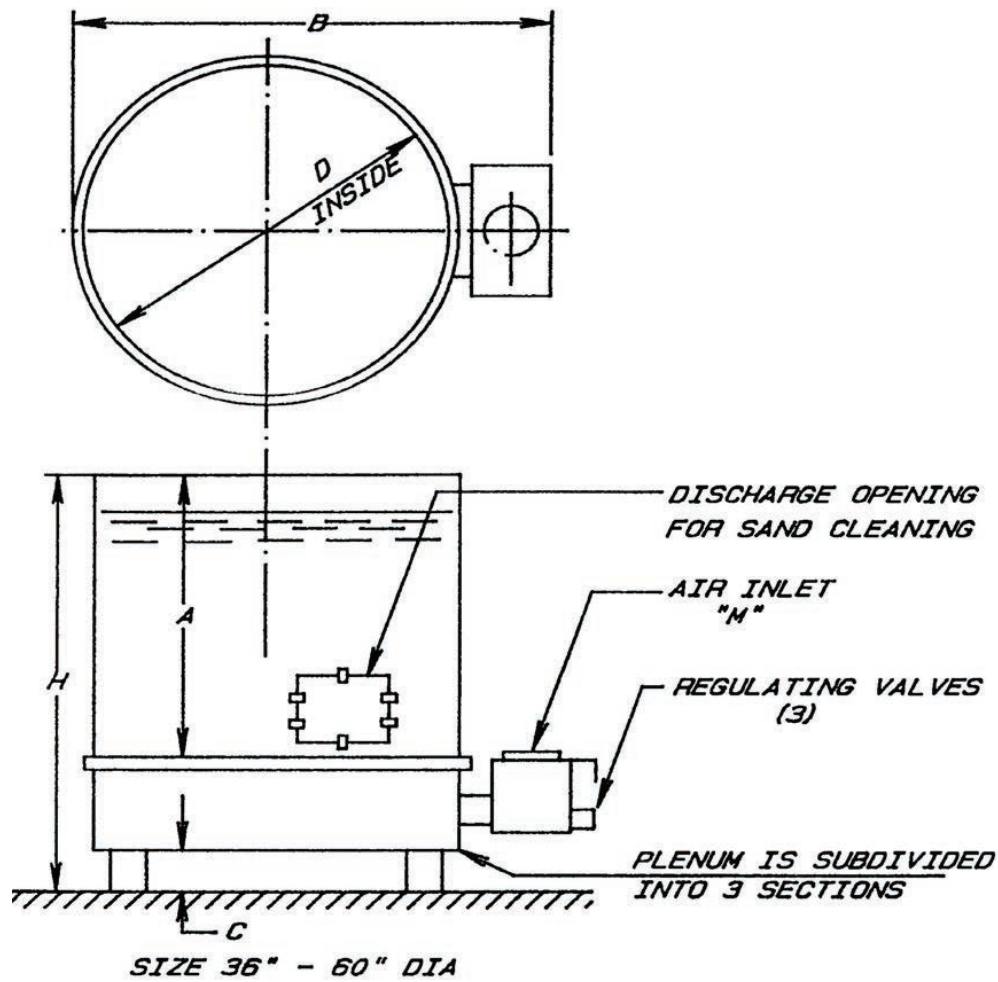

D	H	A	M	B	C
36" 915 mm	40" 1020 mm	32" 815 mm	4"	50.25" 1275 mm	-
40" 1015 mm	44" 1120 mm	32" 815 mm	4"	54.5" 1385 mm	4.5" 115 mm
45" 1145 mm	44" 1120 mm	32" 815 mm	5"	59.5" 1510 mm	4.5" 115 mm
50" 1270 mm	51" 1295 mm	37" 940 mm	6" (8")	68.5" 1740 mm	6.5" 165 mm
53" 1350 mm	51" 1295 mm	37" 940 mm	6" (8")	71.5" 1815 mm	6.5" 165 mm
60" 1525 mm	51" 1295 mm	37" 940 mm	6" (8")	78.5" 1995 mm	6.5" 165 mm

FLUIDIZED BED 23.5" / 600 MM DIA.

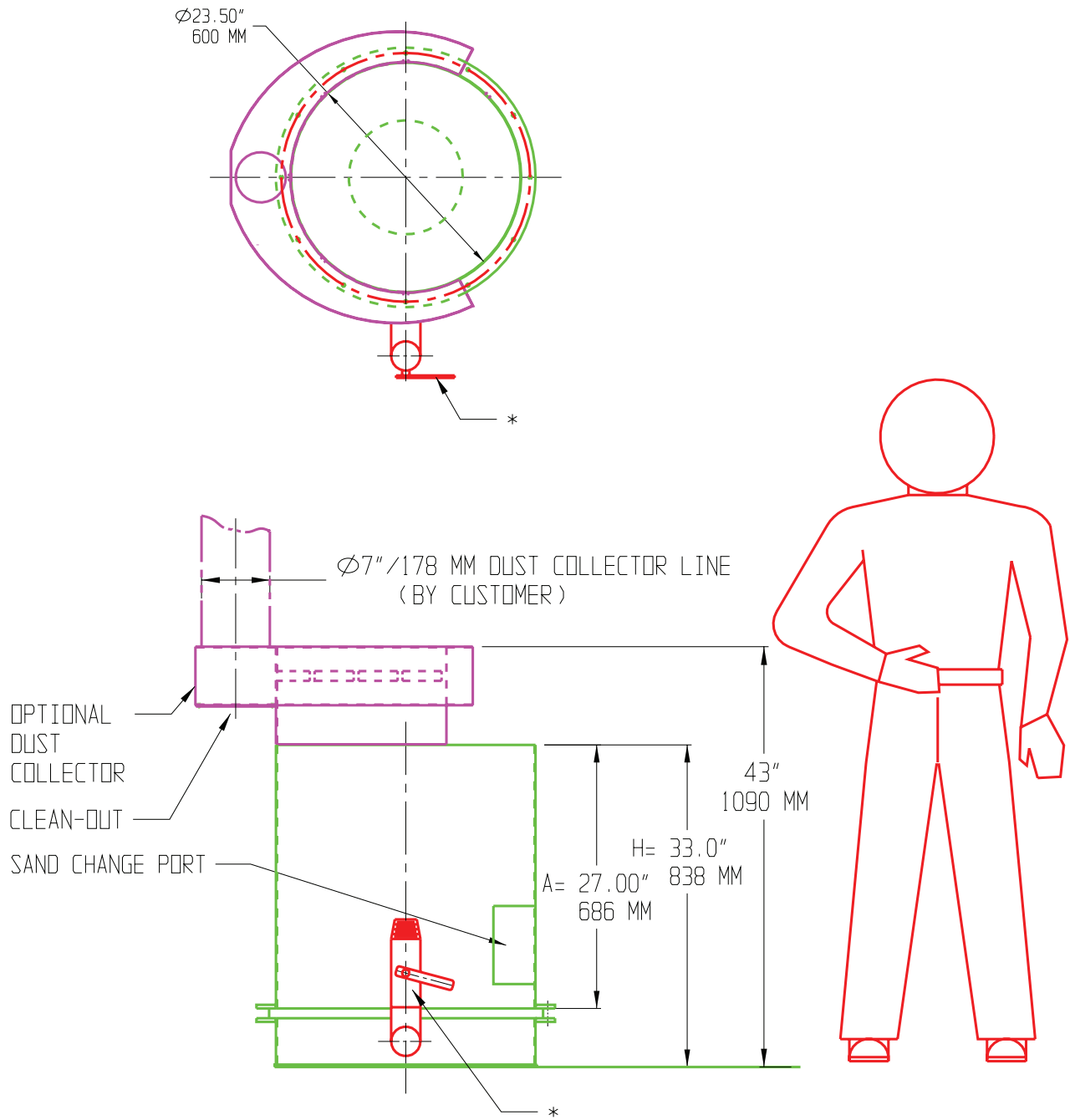

* AIR INLET & REGULATING VALVE 3"

FLUIDIZED BED 2-ZONES, 32"/812 MM DIA.

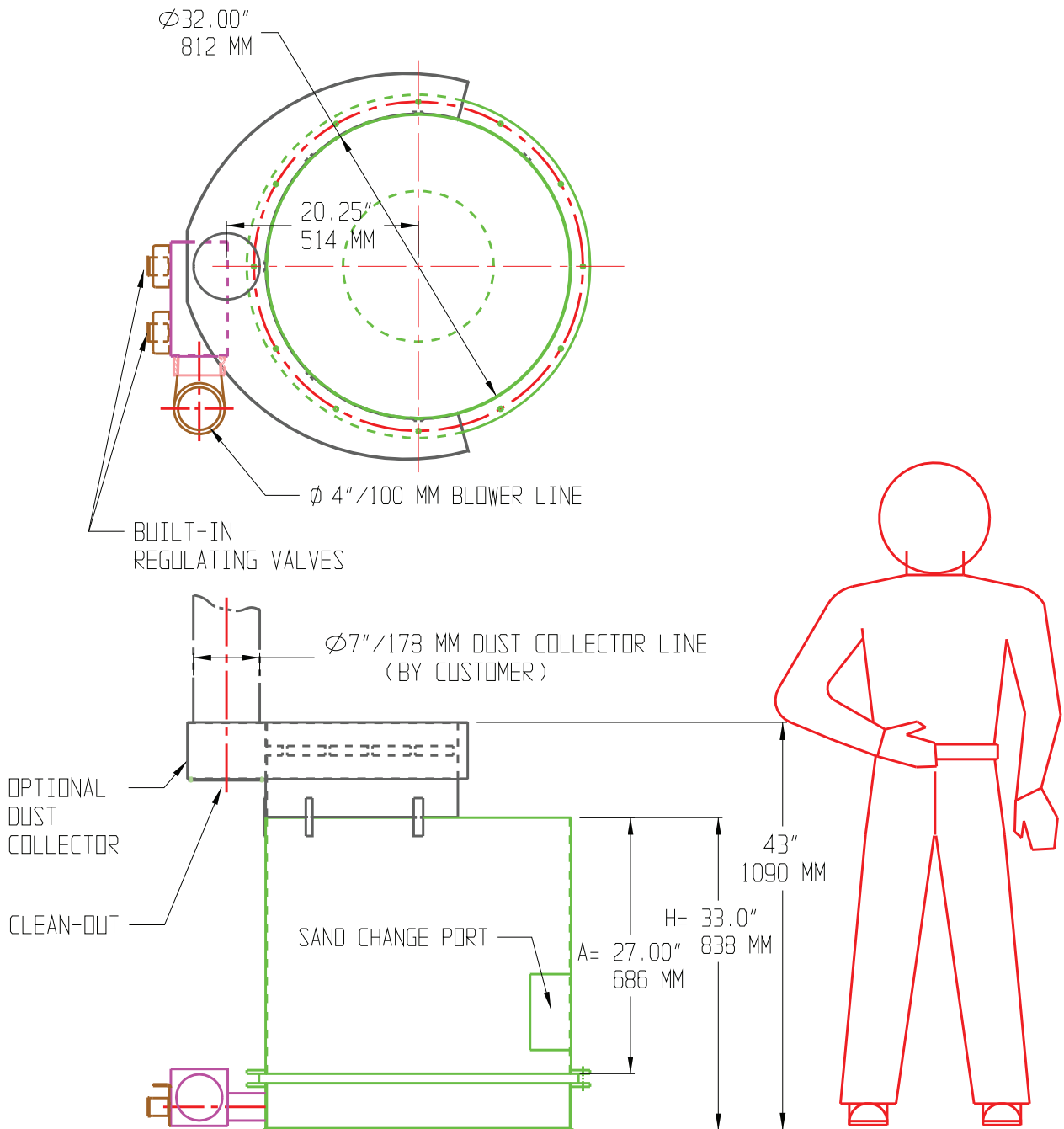

AUTOMATIC HOPPER FEEDER FOR SAND WITH LEVEL CONTROL SYSTEM

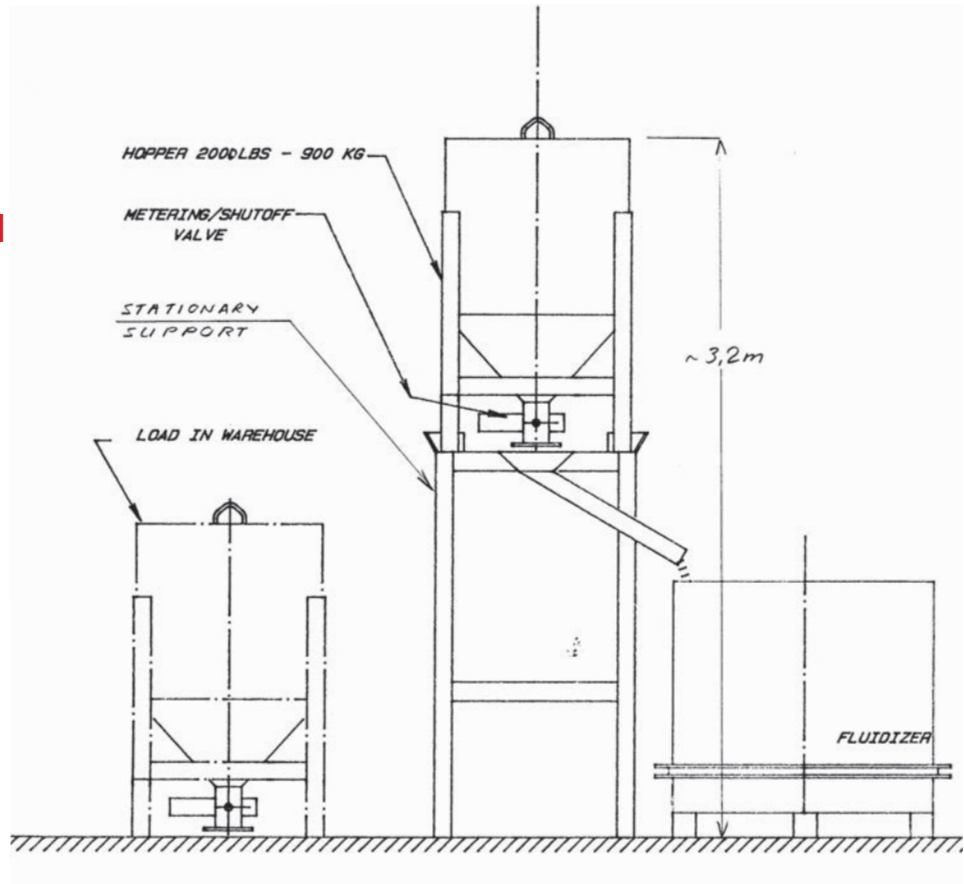

PNEUMATIC HOPPER FEEDER FOR SAND WITH LEVEL CONTROL SYSTEM

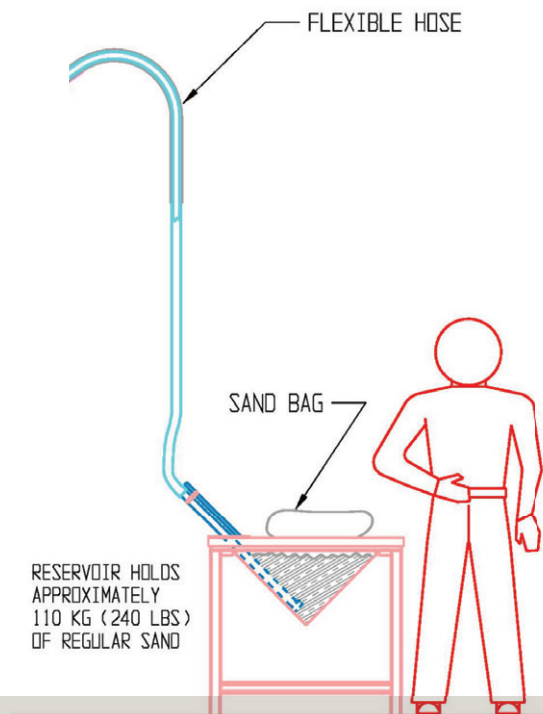

MEZZANINE SAND FEEDING SYSTEM A-22964

When an automated shell building line is producing, nobody likes to see it stop because a sander is out of sand.

This is why we can offer you many automatic replenishment solutions for your sanders. From the well-known gravity-fed system to more sophisticated pneumatic sand feeder, we can offer you standard systems or custom solutions for your more complex needs.

We have one goal in mind: maximize your equipment productivity.

- » Pneumatic or gravity-fed systems available
- » Solution can be tailored to your needs
- » Our specialists can adapt the systems to your specific sands
- » Can be fully automated

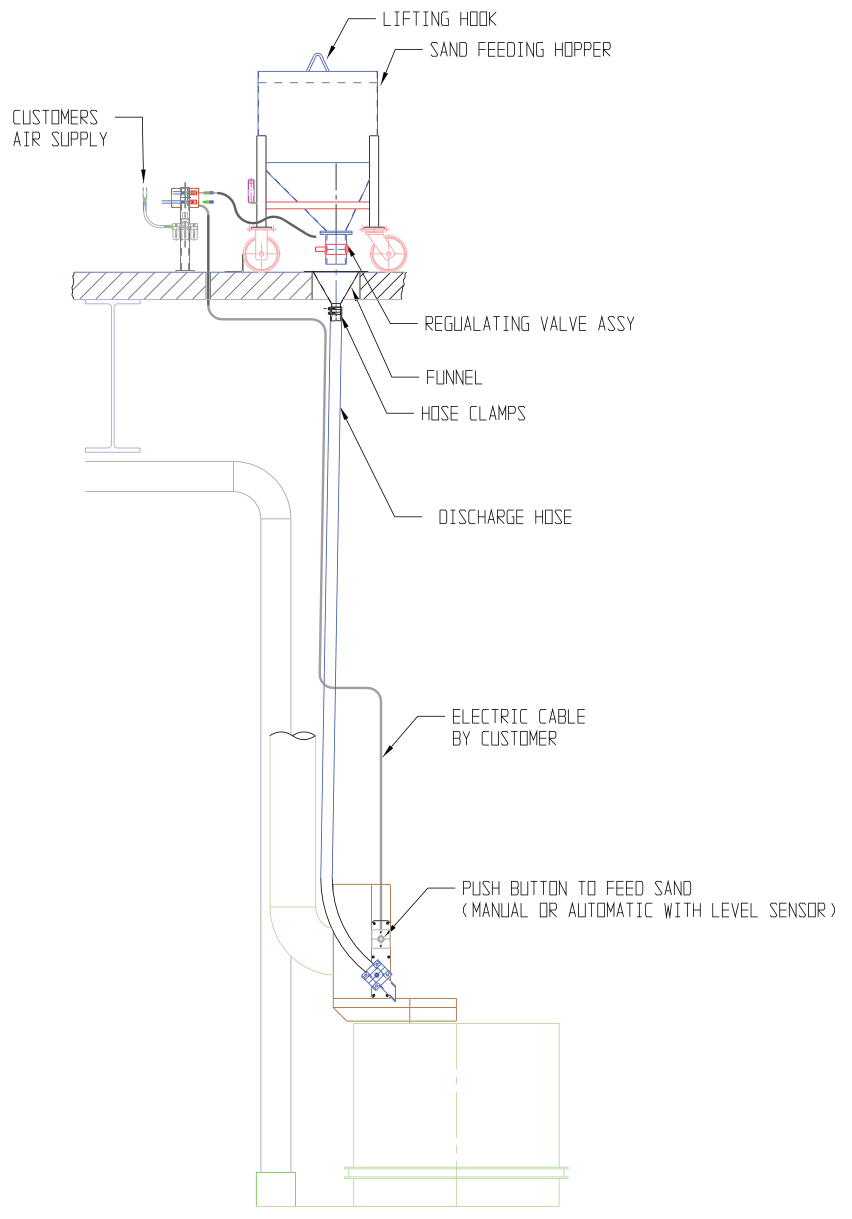

BLOWERS FOR FLUIDIZED BEDS

WHEN IT COMES TO FLUIDIZING SAND, SHELL-O-MATIC HAS THE EXPERIENCE AND EXPERTISE TO HELP YOU.

We go beyond just calculating the air pressure and flow required to fluidize your sand since we have a database of over 140 successful test results recording the proper combination of blower to sand type to ensure proper sand fluidization.

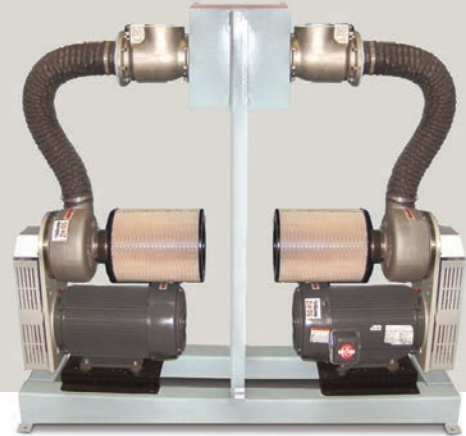

At Shell-O-Matic there is no surprise: you get the right blower to fluidize your sand with proven performance all the time. The blowers we use are high speed, compact and high flow systems that have passed the test of time.

- » Compact design/energy efficient.
- » Reliable solutions that have passed the test of time.
- » Perfect sand fluidization all the time.
- » Dust collection system.
- » Turnkey package with properly sized fluidized bed and blowers for your application.



SMALL MOLD HANDLER

MAX. CAPACITY 70 KG – 160 LBS

AS PARTS, WAX CLUSTERS OR HANGERS BECOME BIGGER AND HEAVIER. HANDLING THEM BECOMES MORE AND MORE OF A CHALLENGE.



This is why Shell-O-Matic created convenient mold handlers that can:

- » Lift the molds up and down like a lift truck
- » Have the forks come closer or apart from each other with a motorized motion
- » Provide assisted forward/backward wheel motion to ease mold carrying
- » Assist wheel motion
- » Can lift parts up and down like a lift truck
- » Forks' opening motion controllable to ease mold pick-up

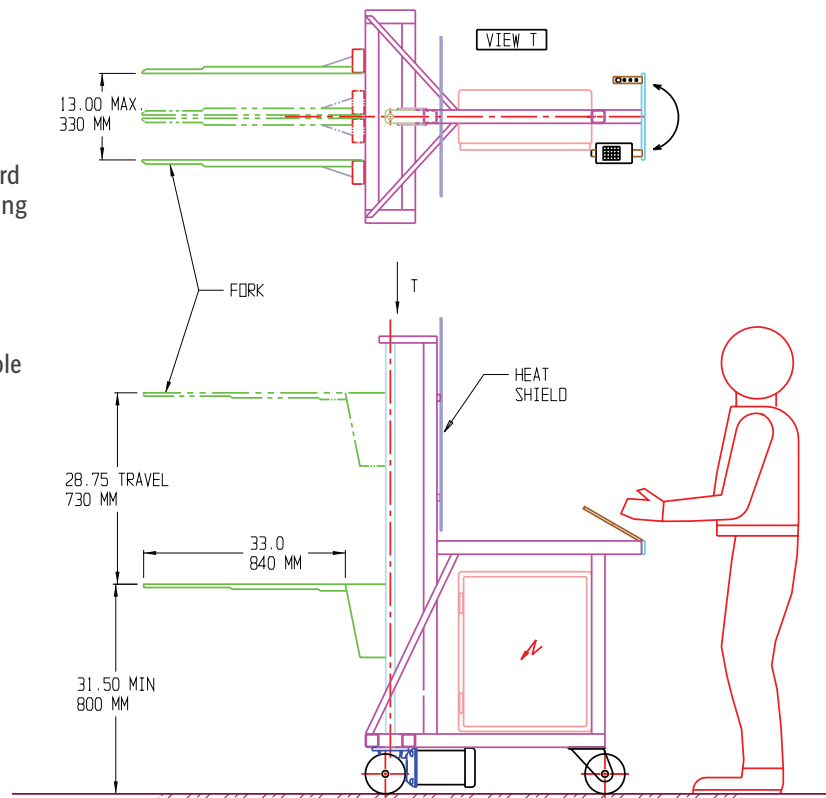

HANDLE YOUR HOT MOLDS WITH EASE

BATTERY OPERATED:
 - FORKS UP / DOWN
 - FORKS IN / OUT

LARGE MOLD HANDLER

MAX. CAPACITY 120 KG – 270 LBS

AS PARTS, WAX CLUSTERS OR HANGERS BECOME BIGGER AND HEAVIER. HANDLING THEM BECOMES MORE AND MORE OF A CHALLENGE.

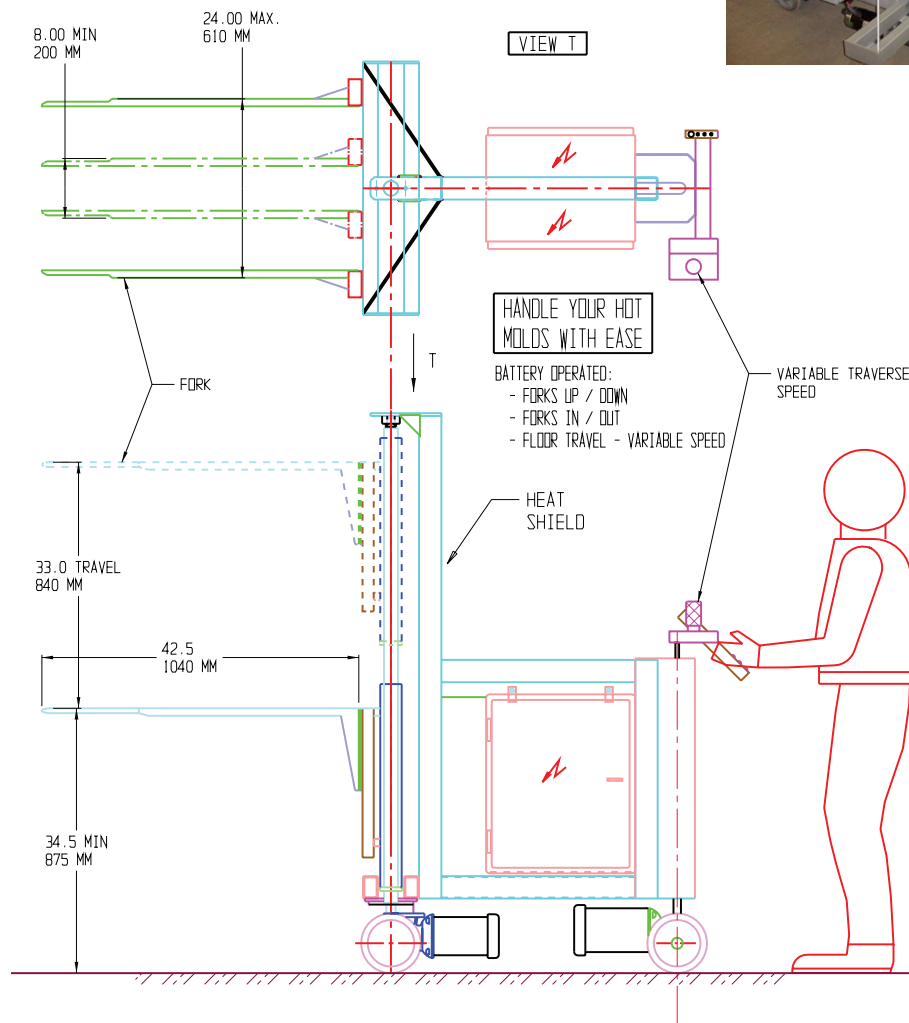
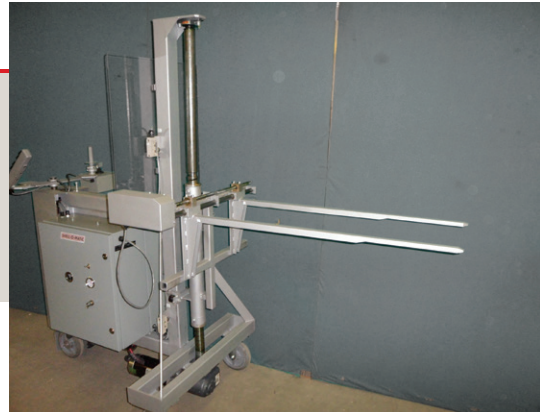

DRY ING SYS TEMS

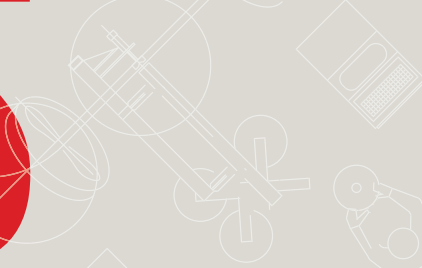
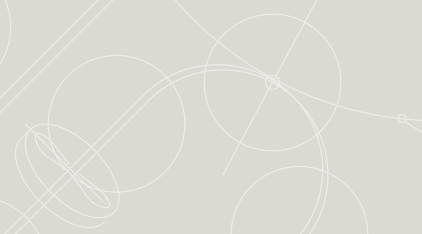
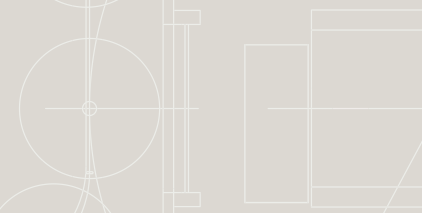
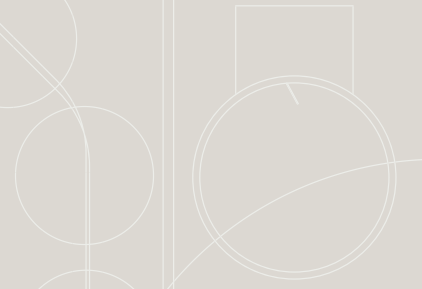

INVESTMENT CASTING SHELL DRYING SYSTEM WITH MICROWAVE

ADVANTAGES & KEY FEATURES

- » Super fast dry
 - Drastic lead time reduction in lost wax shell production. (5 days to 4 hours - 96% reduction rate)
 - Wax temperature kept low - approximately 25C (77F).
- » No shell cracks.
- » Numeric dryness measurement with shell weight change. (PATPEND)
- » Both normal and special slurry applicable.
- » Flexible application.
- » Simple and easy operation.



Dry Shells in Short Time - Only 30 Minutes per Layer

Whereas with conventional methods of shell drying it takes approximately 2 - 3 hours for the 1st and 2nd layer, 3 - 4 hours for 3rd - 5th layers, and 4 - 8 hours for the following layers, Japan High Comm Microwave furnace dries shells only in 30 minutes per layer.

Applications

Application example 1: Full automatic
- Suitable for large item small volume production -



Layout

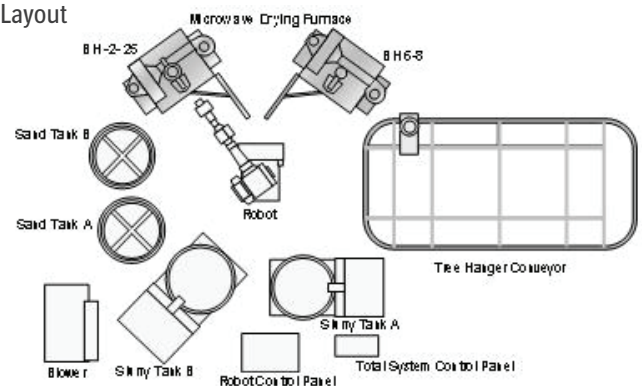

Operation Procedure

- » Unload mold tree from conveyor with robot.
- » Dip mold tree into slurry and coat sand.
- » Put mold tree into multiple microwave drying furnaces by turns.
- » Take out mold tree from microwave drying furnace.

THE DRYING SYSTEM IS A CRITICAL COMPONENT OF THE SHELL BUILDING EQUIPMENT

Its design involves a fine line between shell fast drying to ensure maximum productivity and respecting a minimum shell drying time to avoid shell cracking while allowing the slurry polymers to properly reticulate.

Shell-O-Matic experts can assist you selecting the proper drying system for you from simple open air conveyors to enclosed conveyor tunnels with environmental control, rotating hangers, adjustable fan speed and position. We can also integrate advance drying techniques using infrared or microwaves as an example. We can provide you a turnkey solution from system engineering to installation and training.

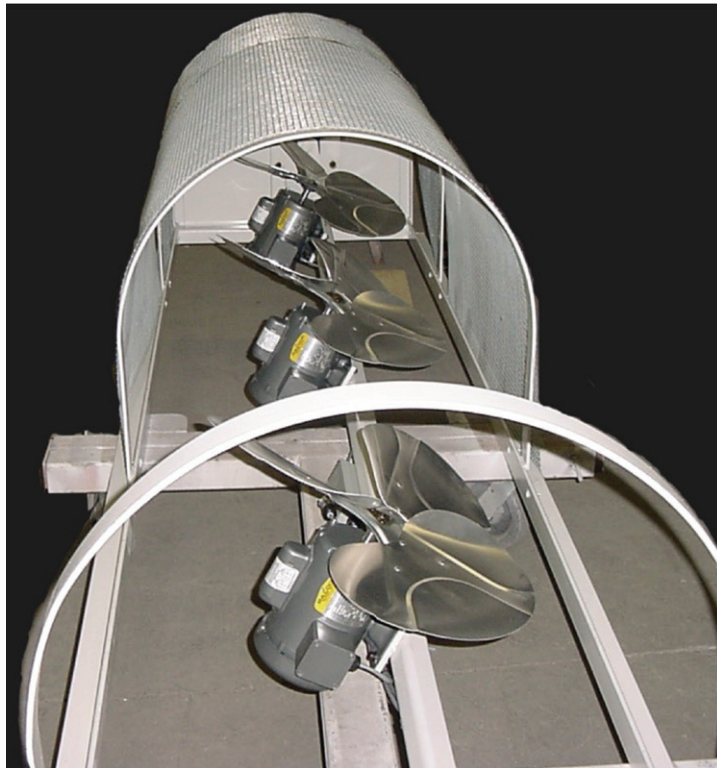

OSCILLATING FAN MODULES WITH VERTICAL AIR FLOW

CONVEYOR SYSTEMS

SHELL-O-MATIC IS SPECIALIZED IN ENGINEERING CUSTOM CONVEYOR SOLUTIONS INTEGRATED WITH ROBOTS TO MEET YOUR PROCESS FLOW, FLOOR SPACE CONSTRAINTS AND MOVE PRODUCTS SAFELY FROM ONE STATION TO ANOTHER.

We have the expertise in automating entire foundries with these systems, allowing for a smooth and automated flow of product towards the factory.

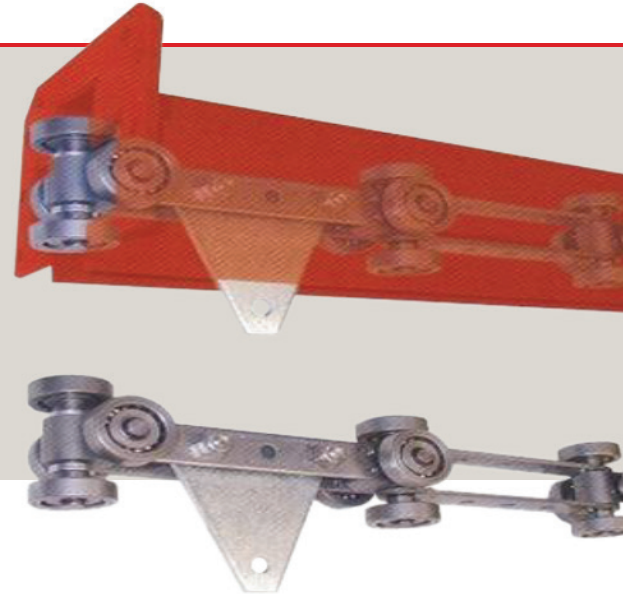

We can provide custom conveyor solutions from engineering to installation. Our conveyor systems are proven in the foundry industry and deliver constant reliable performance at an affordable cost.

- » Many conveyor options to meet the customer load requirement.
- » Turnkey installation all over the world.
- » Customized to match your space constraint.

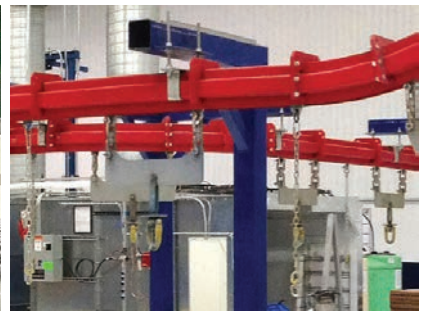

VERTICAL CONVEYOR



SIDE VIEW

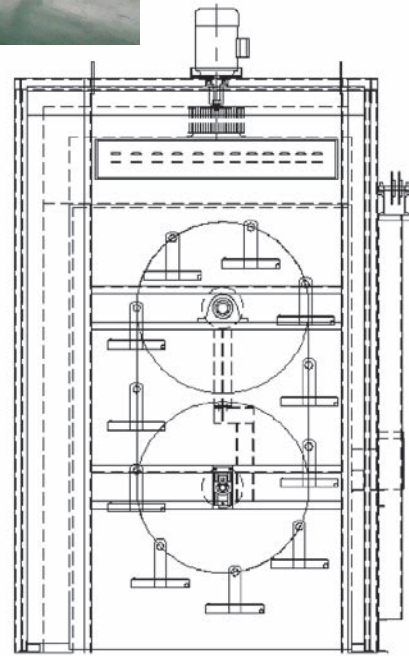
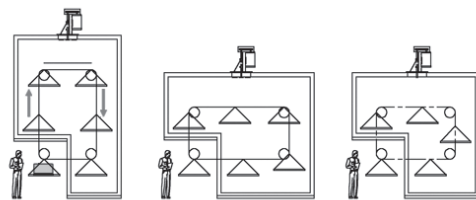

**WAX
DELI
VERY
SYS
TEMS**

The image features a light gray background with a technical drawing aesthetic. The text 'WAX DELIVERY SYSTEMS' is rendered in a bold, red, sans-serif font, stacked vertically. The background is filled with faint white lines and shapes, including circles, rectangles, and various mechanical symbols, creating a complex, schematic-like pattern.

INCREASE PRODUCTIVITY WITH OUR AUTOMATIC WAX MELTER

THE SHELL-O-MATIC WAX MELTER PRODUCT LINE IS DESIGNED TO MELT WAX PASTILLES, FLAKES, BLOCKS OR PLATES AND SCRAP WAX PATTERNS.

The melting temperature is adjustable and relatively high to obtain a good production rate. It is available in 4 models with capacity from 7 kg/hr (15 lbs/hr) to 46 kg/hr (100 lbs/hr) of molten wax.

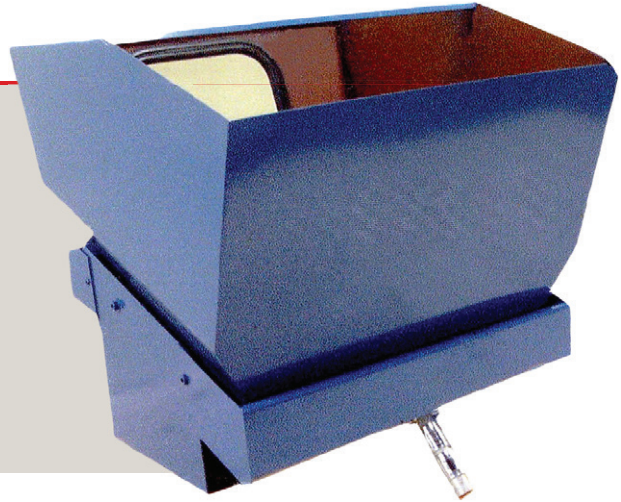

SIZE	APPROX. MELTING CAPACITY AT 200° F (93° C)
No. 1 Mini Melter	15 lbs/hr (7 kg/hr)
No. 2 Standard Melter	30 lbs/hr (14 kg/hr)
No. 3 Large Melter	60 lbs/hr (28 kg/hr)
No. 4 Extra Large Melter	100 lbs/hr (46 kg/hr)



Wax melter and conditioner

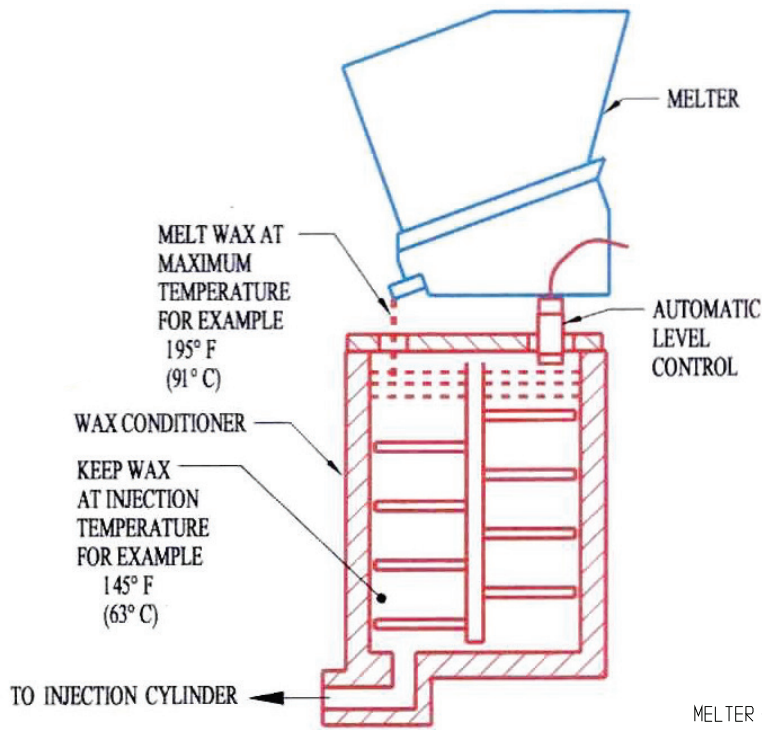

**WAX MELTER WITH
AUTOMATIC FEEDER
FOR PASTILLES**

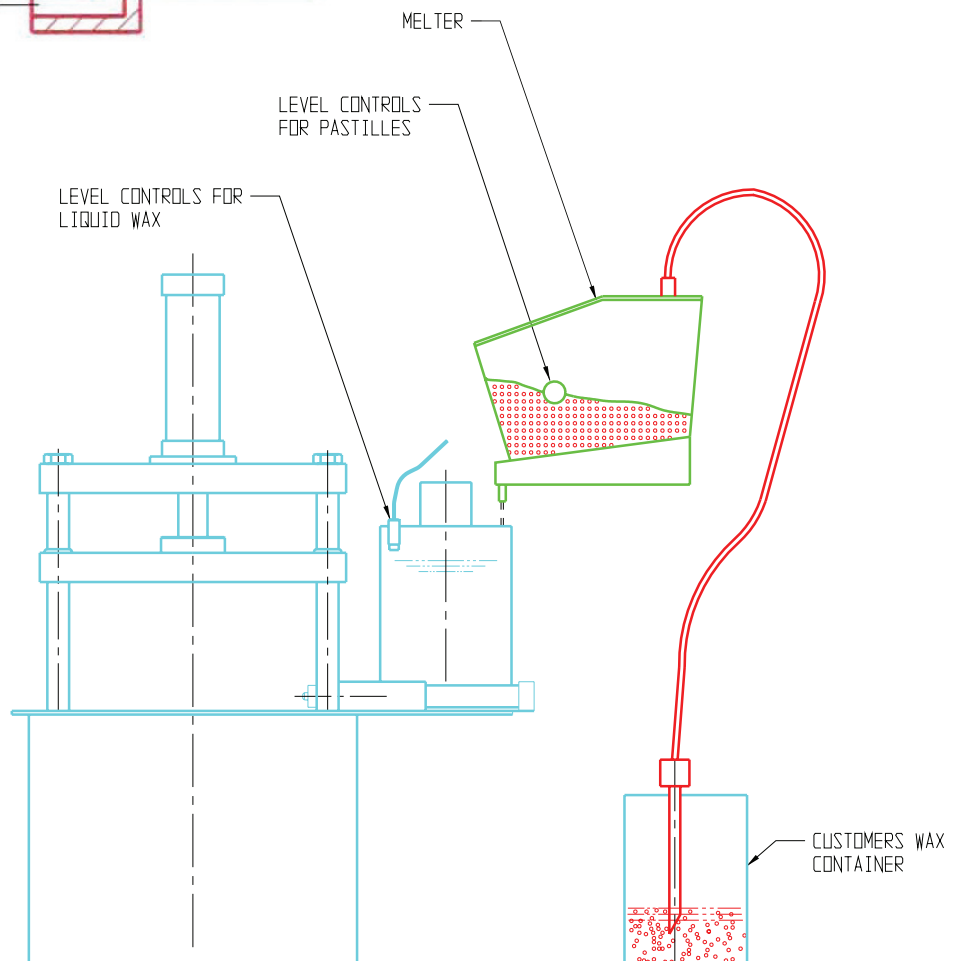

INCREASE PRODUCTIVITY WITH OUR WAX DELIVERY SYSTEM

SHELL-O-MATIC CAN PROVIDE YOU WITH A WAX DELIVERY SYSTEM COMPOSED OF A WAX MELTER AND A WAX CONDITIONER.

The conditioner works in temperature stages and is engineered to prevent air bubbles in the wax. The wax conditioner receives the wax from the melter at the maximum wax temperature and progressively cools it down to the injection temperature. This progressive cooling is key to avoid wax component separation.



The wax level in the conditioner is monitored to ensure it is always properly filled and ready to feed your wax injector system:

- » Avoid formation of air bubbles in the wax
- » Staged cool down to avoid wax element separation
- » Level sensor to ensure the system is always ready to feed the injector

MELTING

The Melting unit melts flakes, slabs or scrap wax on demand by level control.

The single melter rate is approx. 14kg. (30lbs) per hour at 93°C (200°F)

The dual melter will double this rate. The actual melting rate depends on the wax.

CONDITIONING

Adding the new wax in a very liquid state prevents air entrapment. A full sweep agitator produces a homogeneous wax at the precise temperature, ready for injection.

COOLING

In the case of thick wax pattern section it is desirable to inject at a relatively low temperature to eliminate sink and shrinkage problems and to speed up the cycle time.

COOLING (CONTINUED)

Depending on the size of the unit and the wax throughput, the wax temperature can be reduced substantially.

Using low temperature injection competes successfully with the billet extrusion process and allows continuous, uninterrupted operation, eliminating the costly billet handling process.

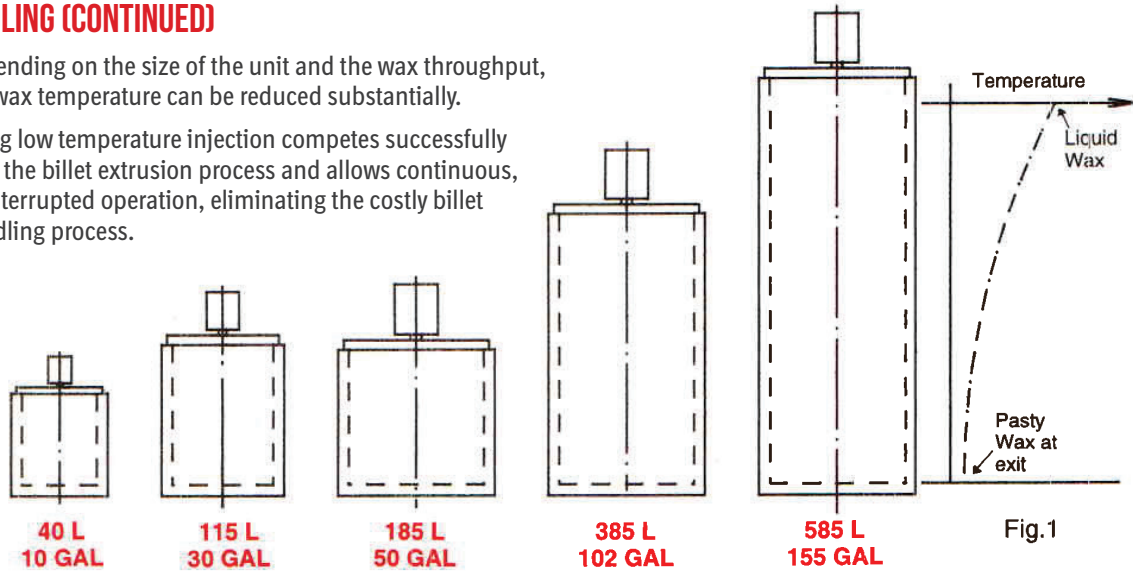

Some models are specifically designed to produce very pasty wax. As it slowly moves down from the top, the wax passes through multiple heating/cooling zones, thereby gradually reducing its temperature, see temperature curve in Fig. 1

A special agitator, slow speed and high torque, ensures the production of consistent, homogeneous pasty wax.

SHELL-O-MATIC BUILDS A COMPLETE RANGE IN 5 SIZES

The separation of the **MELTING** from the **HOLDING** allows the user to operate consistent optimum conditions.

TRANSFER

To transfer the conditioned wax to one or several injectors, a heated pump plus heated flexible or fixed lines can be used.

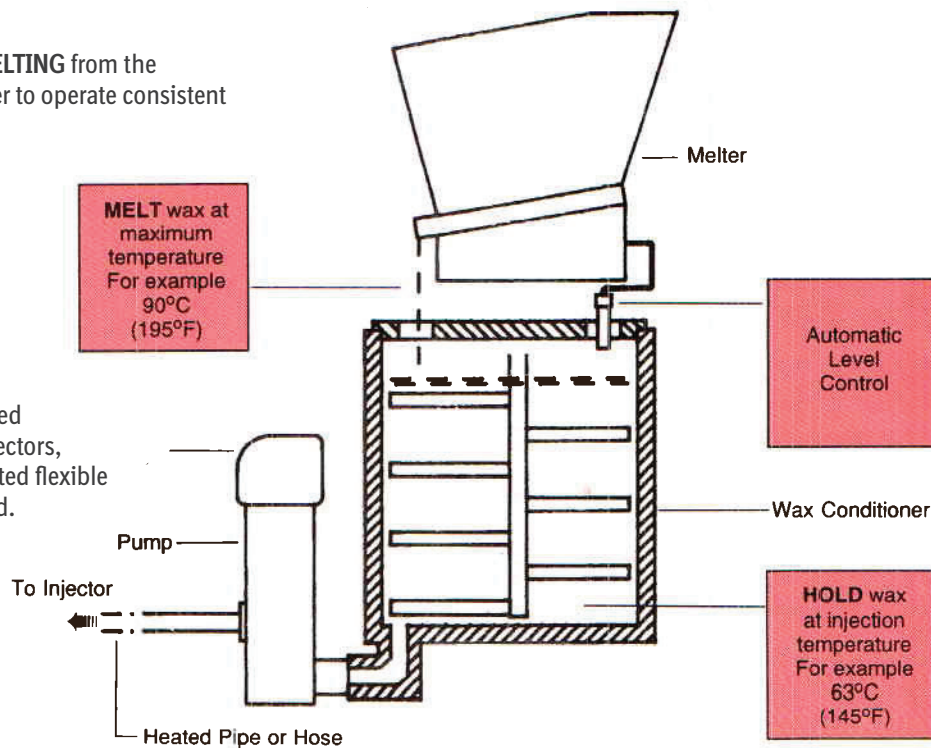

WAX CONDITIONER/COOLER 185 L WITH MELTER

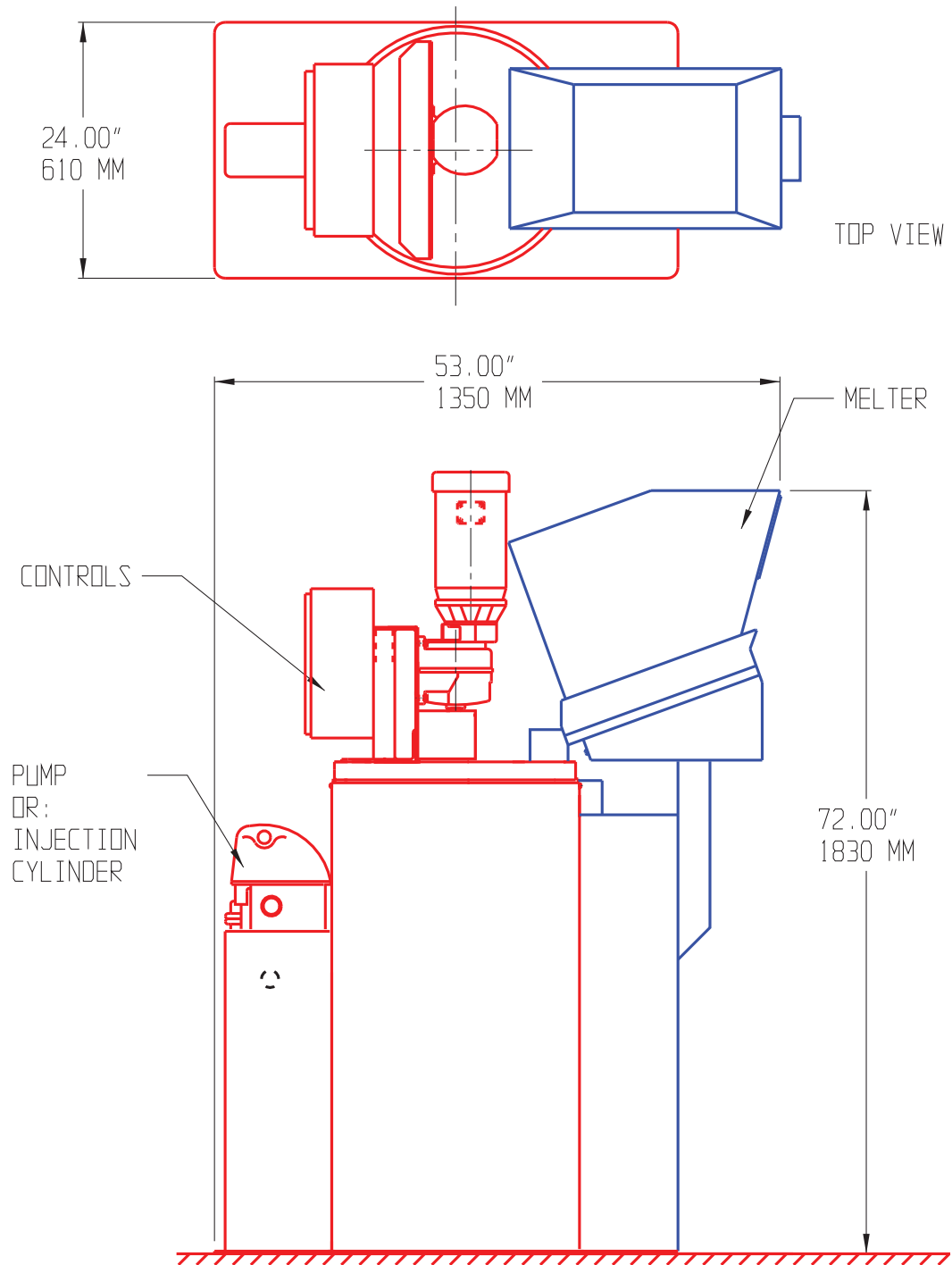

WAX TANK – TABLE TOP MODEL
» FOR STICKY WAX
» FOR SEALING WAX

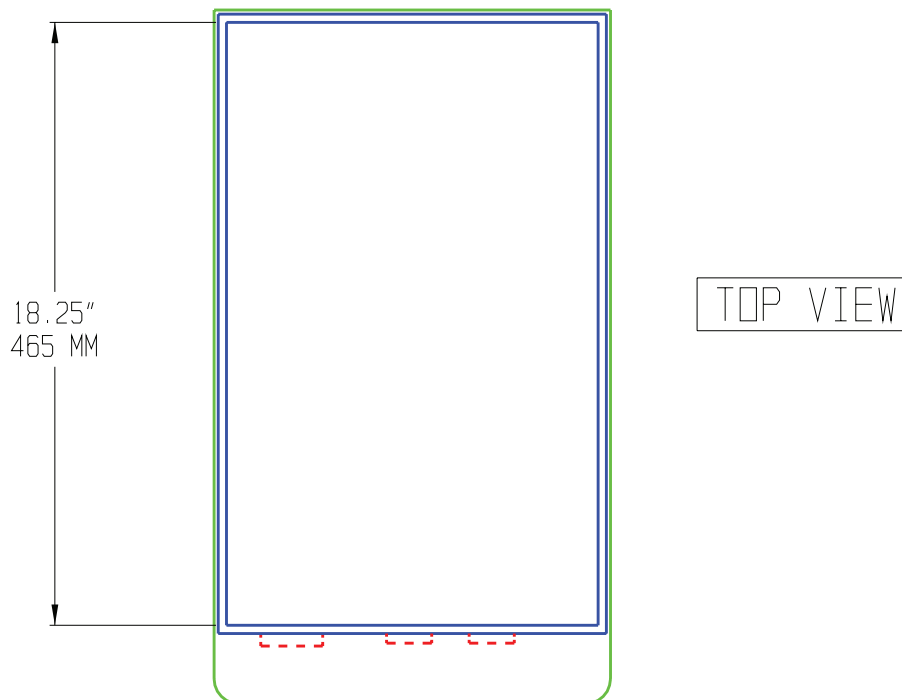
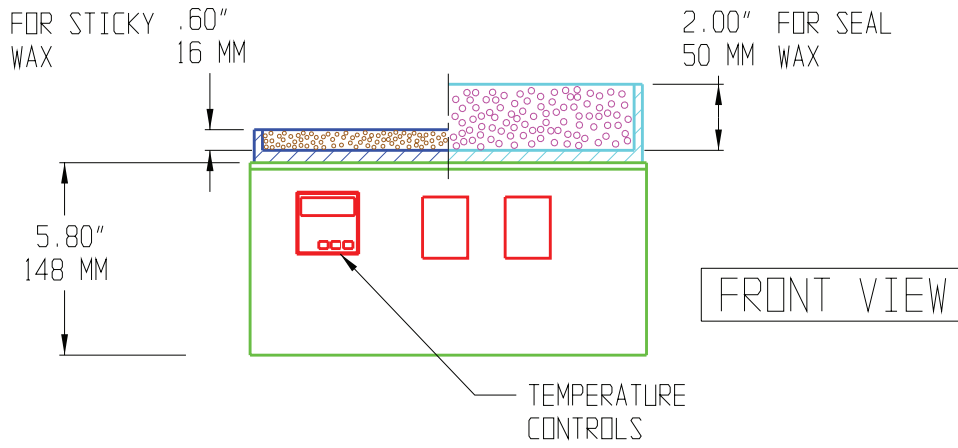

The background is a light gray technical drawing. It features a complex network of thin white lines representing various engineering symbols and components. On the left, there are several circular symbols, some containing internal patterns like a cross or a spiral. In the upper right, there are three rectangular units, possibly representing electrical cabinets or control panels, each with a square symbol on top. At the bottom, there are more symbols, including what looks like a hand holding a tool, a rectangular component with a zigzag line, and other mechanical parts. The overall style is clean and technical.

OTHERS

AERO SERIES

AERO 80 FP DRY ICE BLAST CLEANING SYSTEM

The Aero 80FP Blast Cleaning System comes complete with the following:

- » One length of 1" (2.5 cm) blast hose
- » One length of air hose
- » XP heavy duty applicator
- » Deluxe accessory package
- » Specified nozzle to best suit cleaning application needs
- » Static bond cable and retractable static ground reel
- » Cord wrap
- » Nozzle hanger
- » Hose wrap and hose carrier



AERO 40 FP DRY ICE BLAST CLEANING SYSTEM

The Aero 40FP Series Blast Cleaning System comes complete with the following:

- » One length of 1" (2.5 cm) blast hose
- » One length of air hose
- » XP performance applicator
- » Specified nozzle to best suit cleaning application needs
- » Static bond cable
- » Nozzle hanger
- » Hose wrap and hose carrier



AERO 80FP SPECIFICATIONS

Hopper capacity	80 lbs (36.4 kg) capacity
Hopper type	Isolated, Insulated, Tilt-out
Agitation	Advanced: Thumper, Ramrods, 2x Electric Vibrators
Feeder	Advanced Radial Feeder
Rotor	Enhanced, Coated Stainless Steel
Blast pressure regulator	Internal
Variable feed rate	0 to 7 lbs (0 to 3.2 kg) per min
Blast pressure range	20 to 300 psi (1.4 to 20.7 bar)
Supply pressure range	65 to 300 psi (4.5 to 20.7 bar)
Nozzle air consumption range	50 to 165 cfm (1.4 to 4.7 m ³ /min) at 80 psi (5.5 bar)
Weight	389 lbs (176 kg)
Size (L x W x H)	43" x 20" x 46" (109 cm x 52 cm x 118 cm)
12-month warranty (extended warranty packages available)	

AERO 40FP SPECIFICATIONS

Hopper capacity	40 lbs (18.2 kg) capacity
Hopper type	Isolated, Insulated
Agitation	Performance: Thumper, Ramrods
Feeder	Advanced Radial Feeder
Rotor	Enhanced, Coated Aluminum
Blast pressure regulator	Internal
Variable feed rate	0 to 4.5 lbs (0 to 2 kg) per min
Blast pressure range	20 to 250 psi (1.4 to 17.2 bar)
Supply pressure range	65 to 250 psi (4.5 to 17.2 bar)
Nozzle air consumption range	50 to 165 cfm (1.4 to 4.7 m ³ /min) at 80 psi (5.5 bar)
Weight	257 lbs (117 kg)
Size (L x W x H)	36" x 20" x 40" (91 cm x 51 cm x 102 cm)
12-month warranty (extended warranty packages available)	

WHAT IS DRY ICE CLEANING?

DRY ICE CLEANING, ALSO KNOWN AS DRY ICE BLASTING, IS A REVOLUTIONARY CLEANING METHOD THAT USE DRY ICE PELLETS (CO₂ IN SOLID FORM) AS A BLASTING MEDIA. THE RESULT IS A COMPLETELY DRY, NON-ABRASIVE CLEANING METHOD WITH NO SECONDARY WASTE. DRY ICE IS A FOOD GRADE MEDIA.

DRY ICE CLEANING IS A 3-STEP-PROCESS.

1. Kinetic Effect

Dry ice pellets are accelerated by compressed air to high velocities, thus impacting the layer and provoking fractures.



2. Thermal Effect

The low temperature (-79° C/-110° F) causes the coating to become brittle, crack and loosen. This allows dry ice to permeate the coating.



3. Sublimation

The dry ice turns from solid into gaseous form (sublimates), expanding its volume by a factor of 700. The expansion lifts the coating off the surface.



Save money

- » Lowest cost of ownership
- » LEAN cleaning solution
- » Low maintenance costs

Improve quality

- » Non-abrasive cleaning
- » Reduce scrap
- » Reduce wear and tear

Reduce downtime

- » Increase production time
- » Clean online at operating temperature
- » Clean without dismantling

More flexibility

- » Infinitely adjustable blasting parameters
- » Completely dry cleaning process
- » Clean without secondary waste

An Environmentally Responsible Solution.

Dry ice cleaning is a green substitute for environmentally harmful methods, such as chemicals and solvents. Dry ice provides the perfect, environmentally responsible cleaning media. While materials such as sand, water, etc. become contaminated when they come into contact with hazardous material, dry ice is eco-friendly because it turns into a gas upon contact, and therefore cannot become contaminated like other blasting media.

“The Art of Performance”

With an ergonomic design and simple operation, the Evolution Line provides an efficient and effective cleaning solution that is superior to other methods. Its operational versatility makes it suitable for both lighter applications and heavy duty cleaning.

Your partner in Dry Ice Technology

- » Global experts in dry ice technology
- » Manufacturer with an end user perspective
- » Proven quality from Denmark
- » 24/7 worldwide technical support

40 YEARS
OF INNOVATIVE
EXPERIENCE

SHELL-O-MATIC

SHELL-O-MATIC HAS MAINTAINED ITS POSITION AS A LEADER IN THE INVESTMENT CASTING INDUSTRY BY KEEPING ITS FOCUS ON THE HIGHLY DYNAMIC AND SPECIALIZED FIELDS OF ROBOTICS AND AUTOMATION.

Accumulating decades of experience in automation, experts from key disciplines such as robotics, electronics, mechanics, industrial and software engineering work together to analyze each customer's unique situation and create customized automation solutions for foundries across the world.



GEORGE MURI
Founder and President



SAMUEL BEAUDOIN
General Manager



KLAUS RATHSACK
Operation Manager



DAVID THIBAULT
Service Manager



PHILIPPE FORTIER
Vice President
Business development



SHELL-O-MATIC

CUSTOMIZED HUNDREDS OF HARDWARE
SHELLROOM AND SOFTWARE OPTIONS
SYSTEM ONE SYSTEM THAT IS TAILORED
TO YOUR NEEDS
LET SHELL-O-MATIC
DESIGN IT FOR YOU

**CALL US TO GET YOUR
MAINTENANCE AND SERVICE PACKAGE**

Tailor made maintenance solution from the industry specialist

 **+1.514.323.0868**

10600 Ste Gertrude, Montreal North
QC H1G 5N4 Canada
info@shellomatic.com | shellomatic.com